



EW36FS481VH

EW48FS481VH



PARTS MANUAL



ENCORE MANUFACTURING
A DIVISION OF WORLDSLAWN POWER EQUIPMENT, INC.

ENCOREEQUIPMENT.COM

2415 ASHLAND AVE
BEATRICE, NE 68310
800-267-4255
FAX – 402-223-4103

Content

WHOLE MOWER.....	2
DECK ASM, 36” FIXED.....	3
DECK ASM, 48” FIXED.....	5
ASM, 36” RUBBER DEFLECTOR.....	7
ASM, 48” RUBBER DEFLECTOR.....	8
REAR DECK ASM, 36” HYDRO.....	9
REAR DECK ASM, 48” HYDRO.....	11
HANDLE ASM, HYDRO LOWER.....	13
HANDLE ASM, UPPER H-D.....	14
YOKE CASTER COMPLETE.....	16
POWER ASM, FS481V HYDRO.....	17
FUEL TANK,ASM.....	18
GRP,WHEEL AND HUB.....	19
WIRE.....	20
DECAL.....	21

WHOLE MOWER

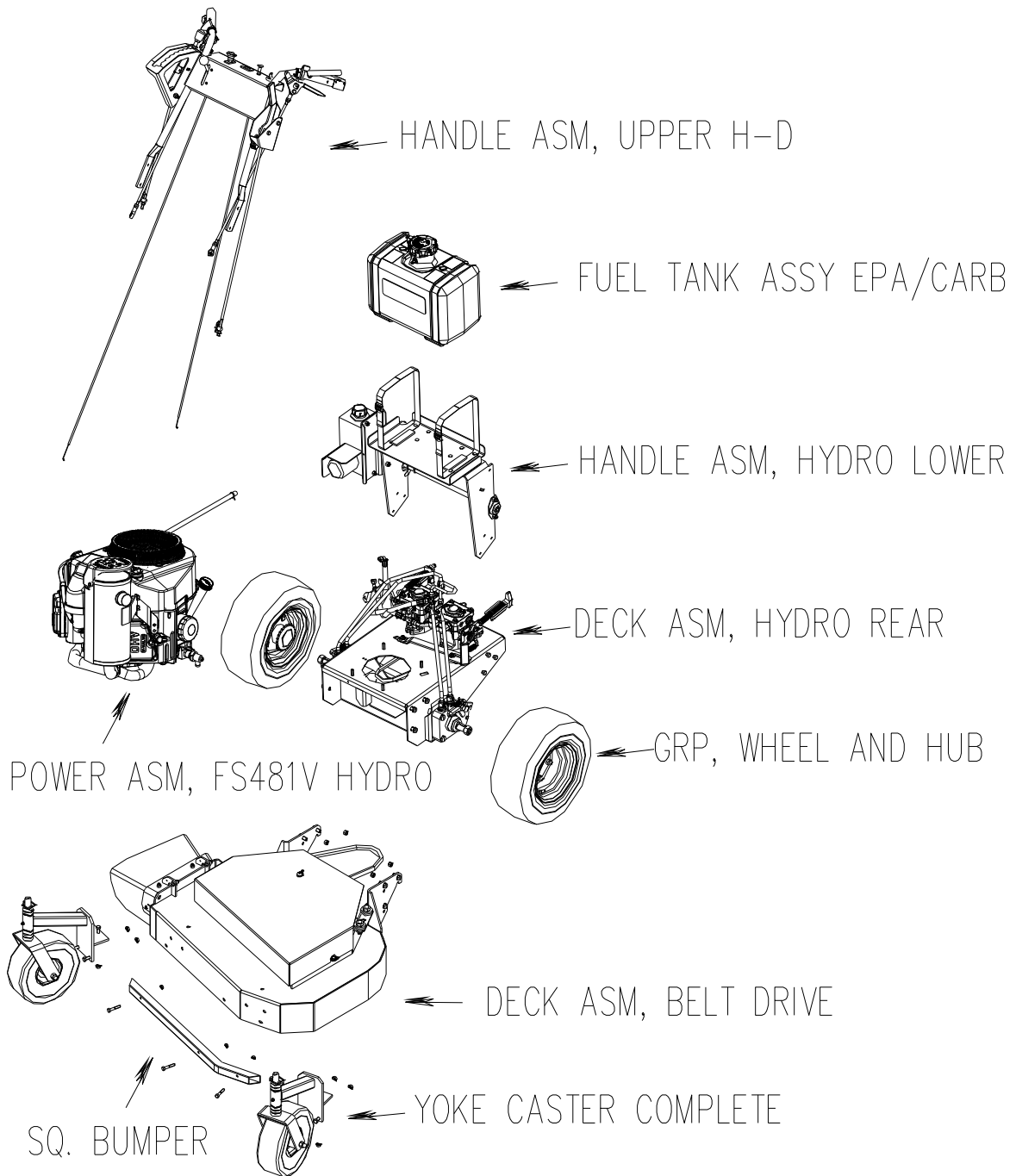



DECK ASM, 36" FIXED

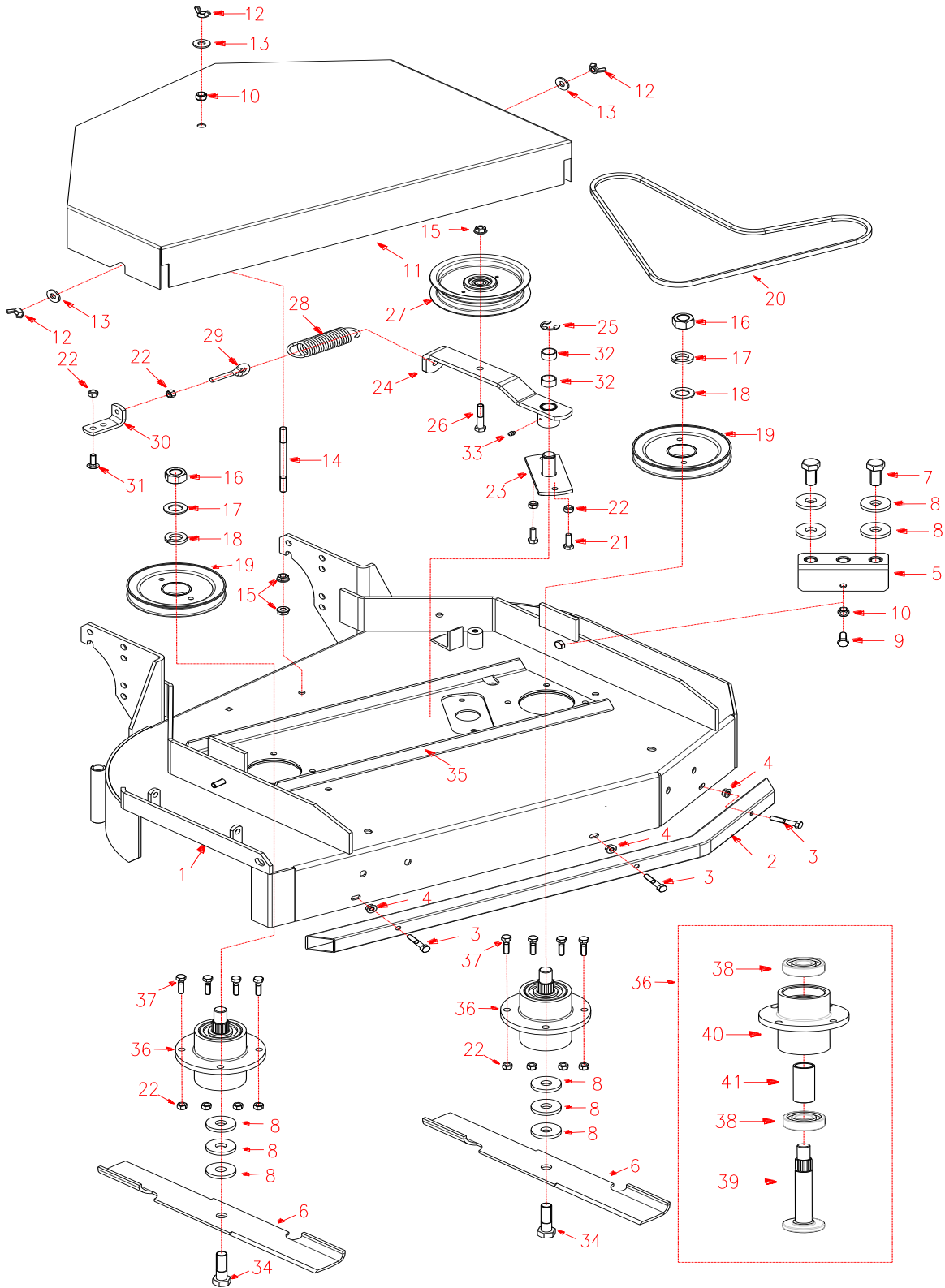



DECK ASM, 36" FIXED

ITEMS	PART NO.	DESCRIPTION	ITEMS	PART NO.	DESCRIPTION
1	362106	36" FRONT DECK WLDMT	22	104256	5/16-18 HEX NYLOC NUT
2	363304	36" SQ. BUMPER	23	362024	IDLER PIVOT ASSY
3	100276	5/16-18 X 1-3/4 HHCS	24	482063	LEVER ASM, DECK IDLER
4	109001	5/16-18 WHIZLOCK NUT	25	108509	E-RING 3/4 DIA.
5	322019	LH Z-BAR	26	100296	3/8-16 X 2 HHCS
6	363291	18" BLADE	27	363264	ENGAGEMENT IDLER
7	100356	5/8-11 X 1-1/2 HHCS	28	523327	FLOATING IDLER SPRING
8	363382	BLADE SPACER	29	363080	EYEBOLT-RIGHT
9	100292	3/8-16 X 1 HHCS	30	523094	SPRING MOUNT-DECK
10	104257	3/8-16 HEX NYLOC NUT	31	107509	5/16-18 X 1 CARR. BOLT
11	362104	BELT SHIELD ASSY	32	363089	ENGAGEMENT-BUSH
12	103027	3/8-16 WINGNUT-PLTD	33	111004	1/4-28 ZERK
13	105260	3/8 STD FLAT WASHER	34	100358	5/8-11 X 2-1/4 HHCS
14	363090	BELT SHIELD SUPPORT	35	363301	DECK CHANNEL - 36"
15	109007	3/8-16 WHIZLOCK NUT	36	363379	CUTTER HOUSING ASSY-W/B
16	104511	3/4-16 UNF REG HEX NUT	37	100274	5/16-18 X 1-1/4 HHTB
17	105010	3/4 LOCKWASHER	38	363350	SKF-6305-FULL-SI-NC-
18	105269	3/4 SAE FLAT WASHER	39	583112	CUTTER SHALFT
19	363378	RAISED PULLEY - 5 3/4	40	363380	BLADE ADAPTER
20	363210	BLADE DRIVE BELT	41	583113	SEPARATE SLEEVE
21	100273	5/16-18 X 1 HHCS			

DECK ASM, 48" FIXED

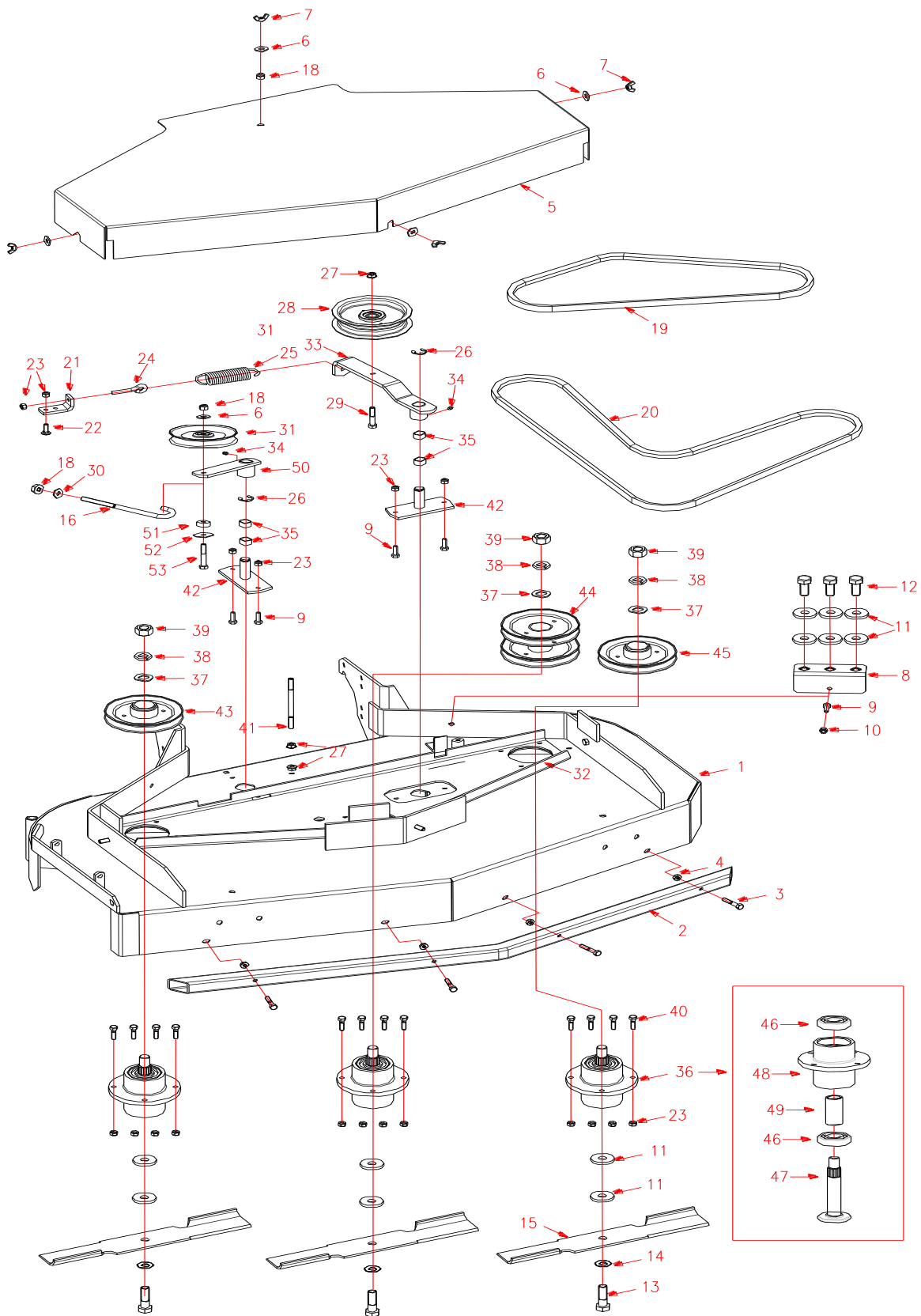



DECK ASM, 48" FIXED

ITEMS	PART NO.	DESCRIPTION	ITEMS	PART NO.	DESCRIPTION
1	482069	48" FRONT DECK W/DECALS	28	363264	ENGAGEMENT IDLER
2	483043	48" SQ. BUMPER	29	100296	3/8-16 X 2 HHCS
3	100276	5/16-18 X 1-3/4 HHCS	30	105260	3/8 STD FLAT WASHER
4	109001	5/16-18 WHIZLOCK NUT	31	483025	RH IDLER PULLEY
5	482067	48" BELT SHIELD W/DECALS	32	482015	48" DECK CHANNEL WLDMT
6	105260	3/8 STD FLAT WASHER	33	482063	LEVER ASM, DECK IDLER
7	103027	3/8-16 WINGNUT	34	111004	1/4-28 ZERK
8	322019	SPACER HOLDER	35	363089	ENGAGEMENT-BUSH
9	100273	5/16-18 X 1 HHCS	36	363379	CUTTER HOUSING ASM
10	104256	5/16-18 HEX NYLOC NUT	37	105269	3/4 SAE FLAT WASHER
11	363382	BLADE SPACER	38	105010	3/4 LOCKWASHER
12	100356	5/8-11 X 1-1/2 HHCS	39	104511	3/4-16 UNF REG HEX NUT
13	100358	5/8-11 X 2-1/4 HHCS	40	100274	5/16-18 X 1-1/4 HHTB
14	583108	5/8 SPRING DISC WASHER	41	363090	BELT SHIELD SUPPORT
15	483035	16" BLADE	42	362024	IDLER PIVOT ASSY
16	483003	BELT TENSION ROD	43	363431	LOWERED PULLEY
17	105260	3/8 STD FLAT WASHER	44	363377	DOUBLE PULLEY - 5 3/4
18	104257	3/8-16 HEX NYLOC NUT	45	363378	RAISED PULLEY - 5 3/4
19	483031	RH BLADE BELT	46	363350	BEARING
20	483030	BLADE DRIVE BELT	47	583112	SPINDLE SHALFT
21	523094	SPRING MOUNT-DECK	48	363380	BEARING BLOCK
22	107509	5/16-18 X 1 CARR. BOLT	49	583113	SEPARATE SLEEVE
23	104256	5/16-18 HEX NYLOC NUT	50	482001	RH IDLER ARM
24	363080	EYEBOLT-RIGHT	51	483017	RH IDLER SPACER
25	108509	E-RING 3/4 DIA.	52	483019	RH IDLER WASHER
26	523327	FLOATING IDLER SPRING	53	100297	3/8-16 X 2-1/4 HHCS
27	109007	3/8-16 WHIZLOCK NUT			

ASM, 36" RUBBER DEFLECTOR

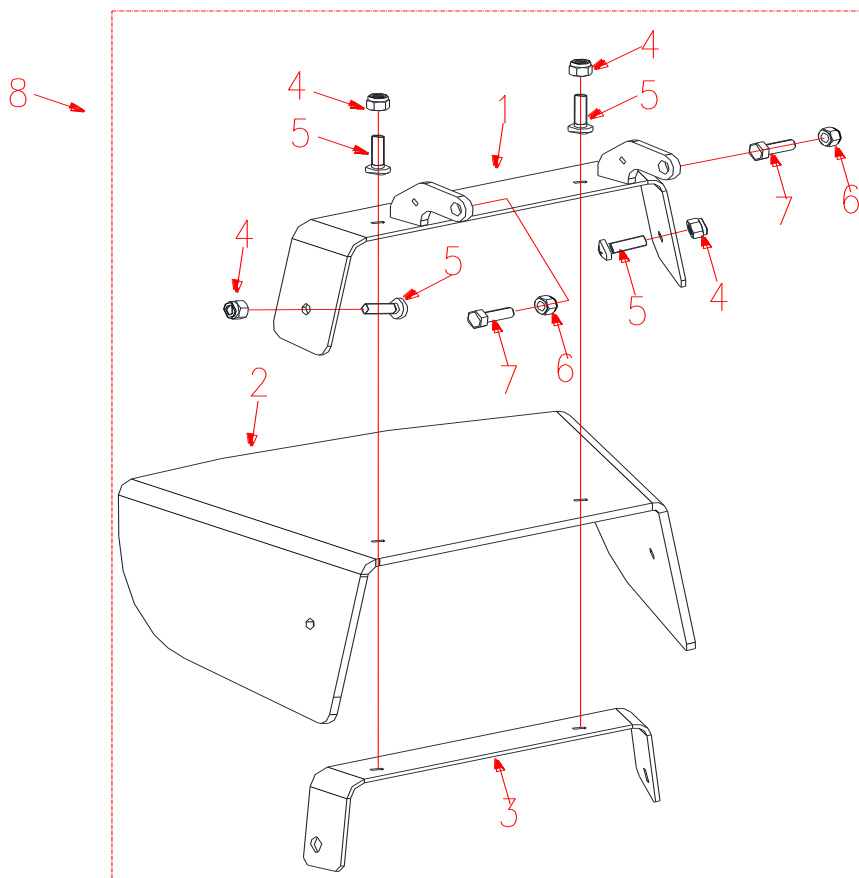

ITEMS	PART NO.	DESCRIPTION
1	482058	WLD, DEFLECTOR BRACKET
2	483118	RUBBER SHEET
3	483130-2	36 INSIDE DEFLECTOR BRACKET - RED
4	B6182-8	NUT, NYLOC M8
5	B818-825	SCREW, M8X25 PHILLIPS PAN
6	104256	5/16-18 HEX NYLOC NUT
7	100273	5/16-18 X 1 HHCS
8	482059	ASM, RUBBER DEFLECTOR

ASM, 48" RUBBER DEFLECTOR

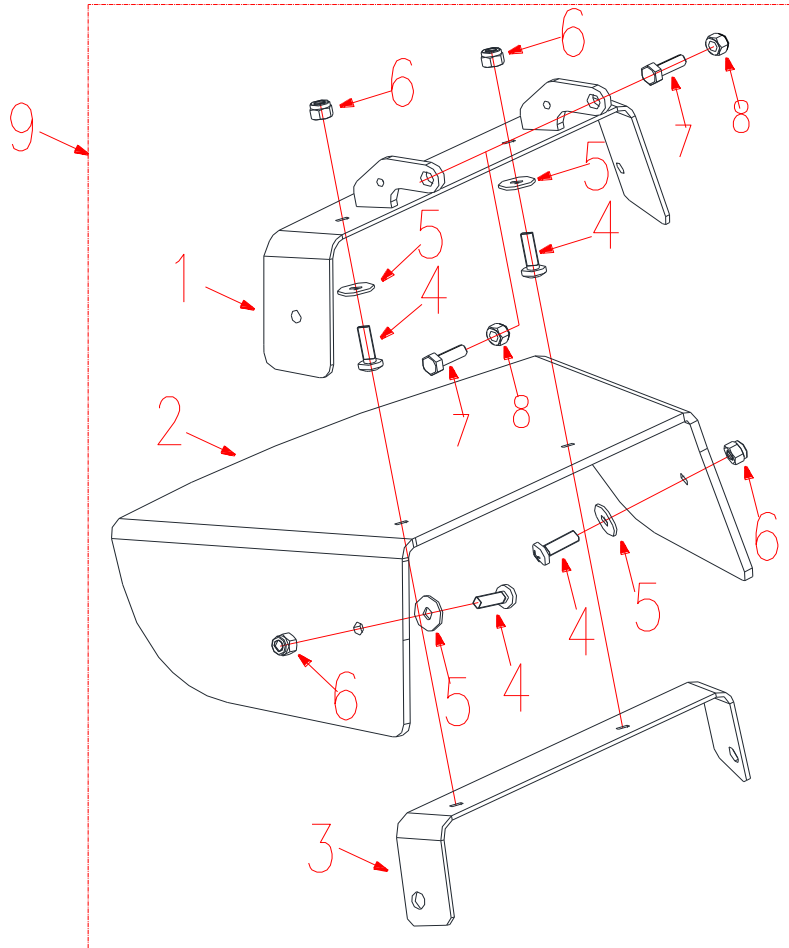

ITEMS	PART NO.	DESCRIPTION
1	482071-2	48" DEFLECTOR BRACKET - RED
2	483132	48" RUBBER SHEET
3	483133-2	48" INSLDE DEFLECTOR BRACKET - RED
4	B818-825	SCREW, M8X25 PHILLIPS PAN
5	B96-8	WASHER 8
6	B6182-8	NUT, NYLOC M8
7	100273	5/16-18 X 1 HHCS
8	104256	5/16-18 HEX NYLOC NUT
9	482072	ASM, 48 RUBBER DEFLECTOR

DECK ASM, 36" HYDRO REAR

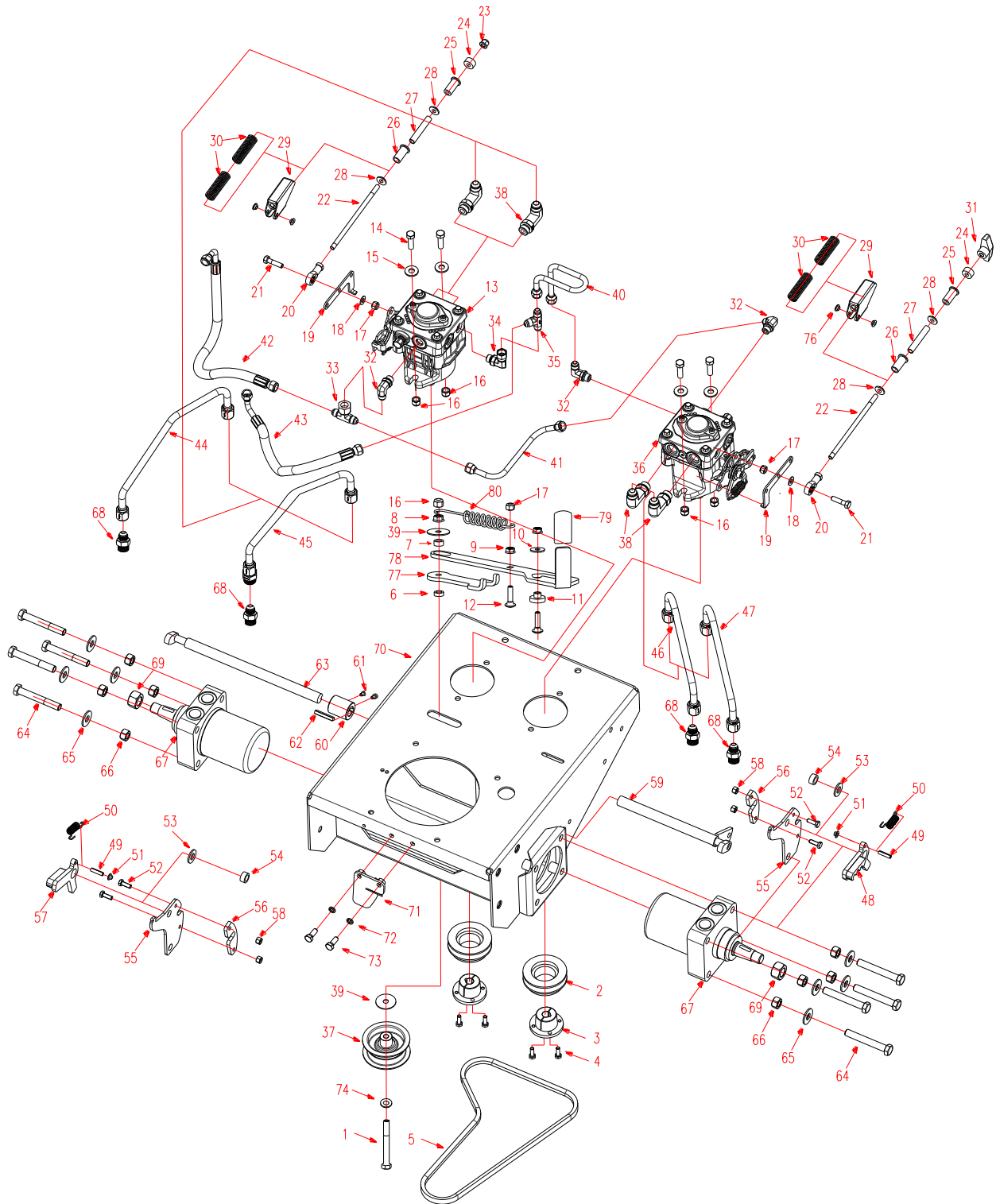



DECK ASM, 36" HYDRO REAR

ITEMS	PART NO.	DESCRIPTION	ITEMS	PART NO.	DESCRIPTION
1	100300	3/8-16 X 3 HHCS	41	453533	TUBE ASM, PUMP RETURN
2	453161	PULLEY, TAPER LOCK	42	453168	TANK HOSE - 16"
3	423178	15MM TAPER HUB	43	453168	TANK HOSE - 16"
4	100252	1/4-20 X 3/4 HHCS	44	453489	TUBE, RH 36 FRONT HYD
5	453536	BELT, PUMP DRIVE	45	453490	TUBE, RH 36 REAR HYD
6	453537	SPACER, CS SLIDE	46	453487	TUBE, LH 36 FRONT HYDRO
7	453573	BUSHING, IDLER HANDLE	47	453488	TUBE, LH 36 REAR HYD
8	109007	3/8-16 WHIZLOCK NUT	48	452154	CLAW WLD, LH PARK BRAKE
9	109001	5/16-18 WHIZLOCK NUT	49	106334	1/4 X 1 ROLL PIN
10	B96-8	WASHER 8	50	363155	OPC SPRING
11	453539	POST, CS LATCH	51	423410	1/4" PAL NUT
12	107529	5/16-18X1-1/2 C-BOLT	52	100252	1/4-20 X 3/4 HHCS
13	453467	PUMP, CW RTN PE	53	105266	1/2 SAE FLAT WASHER
14	100293	3/8-16 X 1-1/4 HHCS	54	423284	BRAKE ARM BUSHING - PLTD
15	105260	3/8 STD FLAT WASHER	55	453460-1	BRACKET, PARK BRAKE - BLK
16	104257	3/8-16 HEX NYLOC NUT	56	423402	CAM ROD RETAINER - PLTD
17	104256	5/16-18 HEX NYLOC NUT	57	452155	CLAW WLD, RH PARK BRAKE
18	105257	5/16 SAE FLAT WASHER	58	104255	1/4-20 HEX NYLOC NUT
19	453468	BRACKET, PUMP LEVER	59	482065	SHAFT WLD, 36" PARK BRAKE
20	5205016	ROD END SIBJK8S	60	483123	COUPLER, BRAKE SHAFT
21	100274	5/16-18 X 1-1/4 HHTB	61	B70.1-510	CAP SCREW, 5 X 10 HEX
22	453459	ROD, SPRING CARTRIDGE	62	B1096B-640	KEY, 6 X 40 SQ
23	B6183-8	NUT, FLANGED NYLOC M8	63	482064	SHAFT WLD, RH PARK BRAKE
24	453472	SPACER, STOP NUT	64	100335	1/2-13 X 4 HHCS
25	453456	BUSHING, ROD GUIDE	65	105264	1/2 STD FLAT WASHER
26	453455	BUSHING, SLEEVE GUIDE	66	104259	1/2-13 HEX NYLOC NUT
27	453458	SLEEVE, STOP	67	453068	WHELMOTOR WB / FC
28	453457	WASHER, SPRING STOP	68	453114	MOTOR ADPT.
29	453454	BRACKET, CARTRIDGE	69	104511	3/4-16 UNF REG HEX NUT
30	453453	SPRING, SPEED CONTROL	70	452148-2	DECK, REAR HYDRO - RED
31	453449	KNOB, 3/8-16 CLAMPING	71	452186	WLD, CLUTCH TORSION
32	453074	90 DEGREE ADAPTER	72	B93-8	LOCKWASHER 8
33	453106	SWIVEL TEE	73	B5783-820	SCREW, HH TAP M8x20
34	453109	SWIVEL ELBOW	74	105259	3/8 SAE FLAT WASHER
35	453020	CROSS ADAPTER	75	107524	5/16-18 X 1-1/4 CARR. BOLT
36	453466	PUMP, CCW RTN PE	76	453576	BUSHING, 6X8X4L FLG
37	393004	PULLEY-CALIPER	77	453571-1	STRUT, IDLER MOUNT - BLK
38	453167	PUMP ADAPTER 90 L	78	453572-1	HANDLE, IDLER - BLK
39	483019	RH IDLER WASHER	79	363022	ADJ. LEVER GRIP
40	453532	TUBE ASM, PUMP SUPPLY	80	3202021	SPRING

DECK ASM, 48" HYDRO REAR

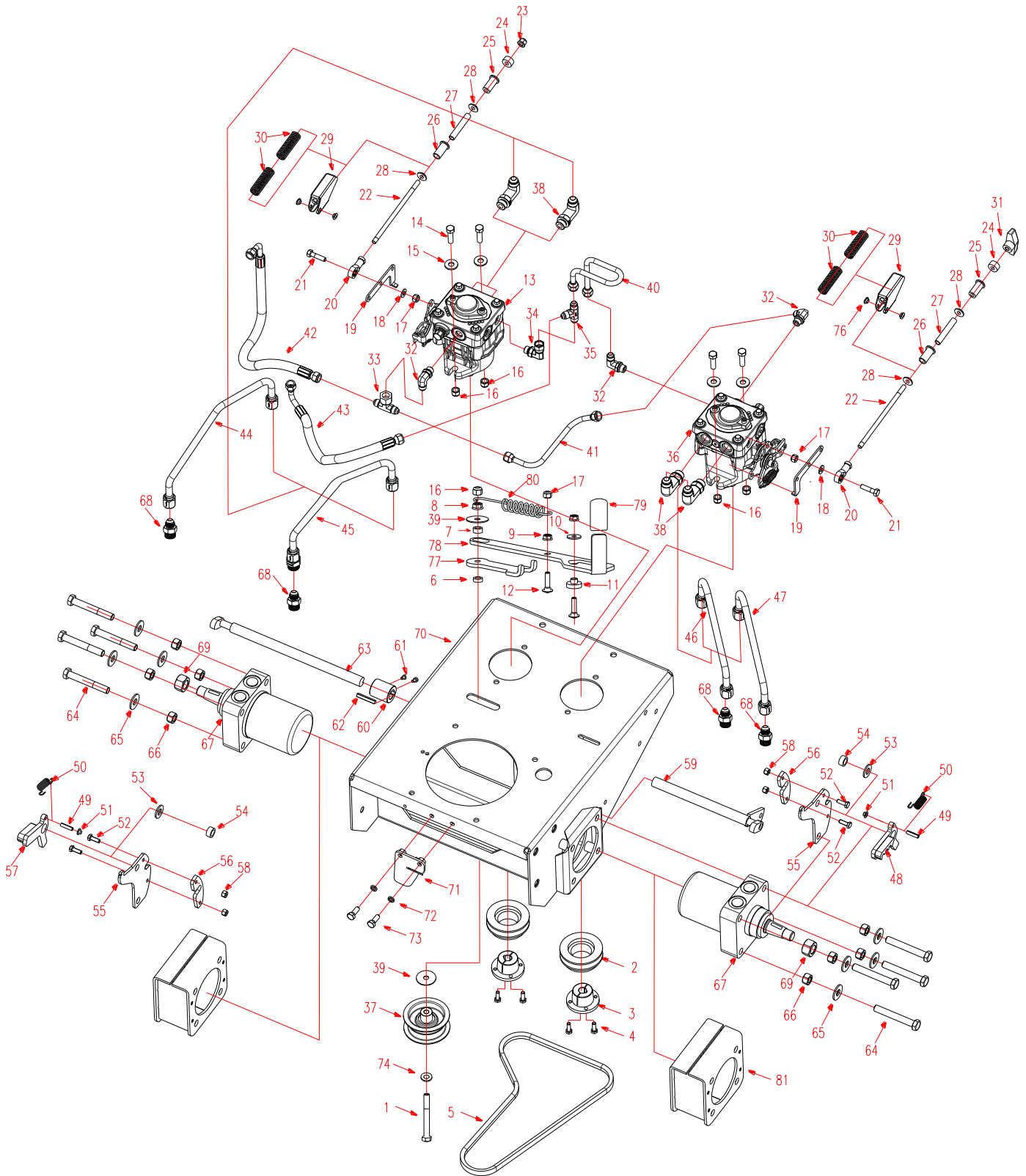



DECK ASM, 48" HYDRO REAR

ITEMS	PART NO.	DESCRIPTION	ITEMS	PART NO.	DESCRIPTION
1	100300	3/8-16 X 3 HHCS	42	453168	TANK HOSE - 16"
2	453161	PULLEY TAPER LOCK	43	453168	TANK HOSE - 16"
3	423178	15MM TAPER HUB	44	453489	TUBE, RH 36 FRONT HYD
4	100252	1/4-20 X 3/4 HHCS	45	453490	TUBE, RH 36 REAR HYD
5	453536	BELT, PUMP DRIVE	46	453487	TUBE, LH 36 FRONT HYDRO
6	453537	SPACER, CS SLIDE	47	453488	TUBE, LH 36 REAR HYD
7	453573	BUSHING, IDLER HANDLE	48	452154	CLAW WLD, LH PARK BRAKE
8	109007	3/8-16 WHIZLOCK NUT	49	106334	1/4 X 1 ROLL PIN
9	109001	5/16-18 WHIZLOCK NUT	50	363155	OPC SPRING
10	B96-8	WASHER 8	51	423410	1/4" PAL NUT
11	453539	POST, CS LATCH	52	100252	1/4-20 X 3/4 HHCS
12	107529	5/16X1-1/2 C BOLT	53	105266	1/2 SAE FLAT WASHER
13	453467	PUMP, CW RTN PE	54	423284	BRAKE ARM BUSHING - PLTD
14	100293	3/8-16 X 1-1/4 HHCS	55	453460-1	BRACKET, PARK BRAKE - BLK
15	105260	3/8 STD FLAT WASHER	56	423402	CAM ROD RETAINER - PLTD
16	104257	3/8-16 HEX NYLOC NUT	57	452155	CLAW WLD, RH PARK BRAKE
17	104256	5/16-18 HEX NYLOC NUT	58	104255	1/4-20 HEX NYLOC NUT
18	105257	5/16 SAE FLAT WASHER	59	482065	SHAFT WLD, 36" PARK BRAKE
19	453468	BRACKET, PUMP LEVER	60	483123	COUPLER, BRAKE SHAFT
20	5205016	Bearing SIBJK8S	61	B70.1-510	CAP SCREW, 5 X 10 HEX
21	100274	5/16-18 X 1-1/4 HHTB	62	B1096B-640	KEY, 6 X 40 SQ
22	453459	ROD, SPRING CARTRIDGE	63	482064	SHAFT WLD, RH PARK BRAKE
23	B6183-8	NUT, FLANGED NYLOC M8	64	100335	1/2-13 X 4 HHCS
24	453472	SPACER, STOP NUT	65	105264	1/2 STD FLAT WASHER
25	453456	BUSHING, ROD GUIDE	66	104259	1/2-13 HEX NYLOC NUT
26	453455	BUSHING, SLEEVE GUIDE	67	453068	WHEELMOTOR WB / FC
27	453458	SLEEVE, STOP	68	453114	MOTOR ADPT.
28	453457	WASHER, SPRING STOP	69	104511	3/4-16 UNF REG HEX NUT
29	453454	BRACKET, SPRING CARTRIDGE	70	452148-2	DECK, REAR HYDRO - RED
30	453453	SPRING, SPEED CONTROL	71	452186	WLD, CLUTCH TORSION
31	453449	KNOB, 3/8-16 CLAMPING	72	B93-8	LOCKWASHER 8
32	453074	90 DEGREE ADAPTER	73	B5783-820	SCREW, HH TAP M8X20
33	453106	SWIVEL TEE	74	105259	3/8 SAE FLAT WASHER
34	453109	SWIVEL ELBOW	75	107524	5/16-18 X 1-1/4 C BOLT
35	453020	CROSS ADAPTER	76	453576	BUSHING, 6X8X4L FLG
36	453466	PUMP, CCW RTN PE	77	453571-1	STRUT, IDLER MOUNT - BLK
37	393004	PULLEY-CALIPER	78	453572-1	HANDLE, IDLER - BLK
38	453167	PUMP ADAPTER 90 L	79	363022	ADJ. LEVER GRIP
39	483019	RH IDLER WASHER	80	3202021	SPRING
40	453532	TUBE, PUMP SUPPLY	81	452026	MOTOR EXTENSION
41	453533	TUBE, PUMP RETURN			

HANDLE ASM, HYDRO LOWER

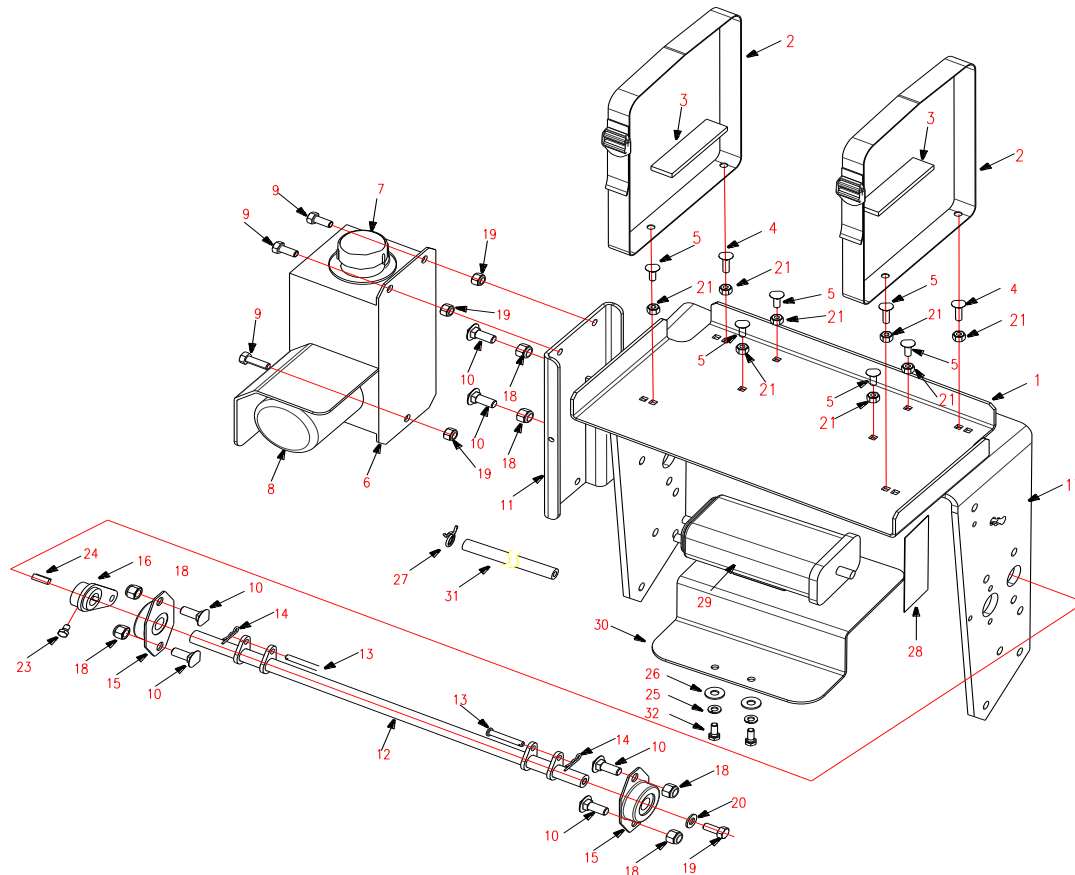

ITEM S	PART NO.	DESCRIPTION	ITEM S	PART NO.	DESCRIPTION
1	363420	FUEL TANK MNT-PAINTED	18	104257	3/8-16 HEX NYLOC NUT
2	363368	GAS TANK BELT	19	104256	5/16-18 HEX NYLOC NUT
3	363201	FUEL TANK PAD	20	105257	5/16 SAE FLAT WASHER
4	107510	1/4-20 X 1 C BOLT	21	104255	1/4-20 HEX NYLOC NUT
5	107502	1/4-20 X 3/4 C BOLT	22	363410	FUEL TANK ASSY EPA/CARB
6	452120-1	WLD, ICT OIL TANK	23	B5783-58	SCREW, HH TAP M5 X 8
7	453375	CAP, OIL TANK ICT	24	107253	3/16 X 3/16 X 1/2 KEY
8	423361	OIL FILTER	25	105004	1/4 LOCKWASHER
9	100271	5/16-18 X 3/4 HHCS	26	105256	WASHER, FLAT USS 1/4
10	107526	3/8-16 X 1 CARR. BOLT	27	363098	CLAMP, FUEL LINE
11	452147-1	MOUNT, OIL TANK - BLK	28	363416	LABEL, EPA-WB
12	452144	SHAFT WLD, PUMP CONTROL	29	363423	SM CARBON CANISTER
13	B882B-645	PIN, 6 X 45 CLEVIS	30	363426	CARBON CANISTER MT
14	XSZ56-1-17	HAIRPIN COTTER	31	603032	FUEL LINE-16&18 BRIGGS
15	363292	FLANGED BEARING	32	B5783-616	SCREW, HH TAP M6X16
16	452163	LEVER WLD, CNTL SHAFT			
17	453452-1	LOWER HANDLE			

HANDLE ASM, UPPER H-D

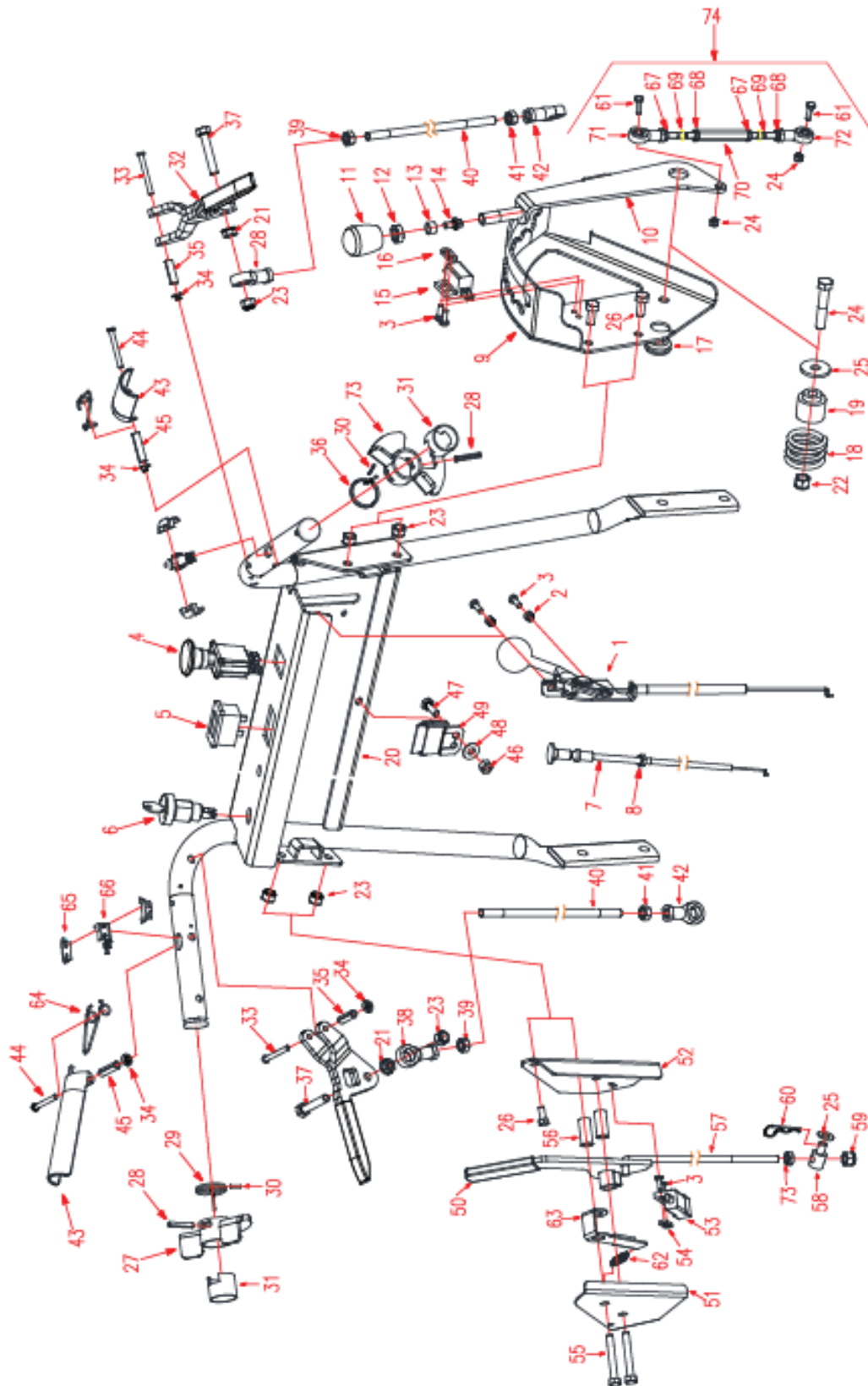

HANDLE ASM, UPPER H-D



ITEMS	PART NO.	DESCRIPTION	ITEMS	PART NO.	DESCRIPTION
1	453531	CABLE, THROTTLE	38	5205017	ROD END SILBJK8S (LH)
2	B6182-5	NUT, NYLOC M5	39	B6171-8L	NUT M8 (LH)
3	B823-514	SCREW, M5 X 14 PAN HD	40	454118	ROD ASM, DRIVE CONTROL
4	523031	PTO SWITCH	41	B6171-8	NUT M8
5	453417	METER, MS HOUR	42	5205016	ROD END SIBJK8S
6	603060	RUN/STOP SWITCH	43	453581	LEVER, OPC PALM
7	523037	CHOKE CABLE	44	453520	PIN, OPC LEVER PIVOT
8	104754	3/8-24 HEX JAM NUT	45	106342	5/16X1-1/4 ROLL PIN PLTD
9	452166	PANEL, SPEED CONTROL	46	104255	1/4-20 HEX NYLOC NUT
10	452168	LEVER, SPEED CONTROL	47	100252	1/4-20 X 3/4 HHCS
11	B4141.13-1240	KNOB, M12 MACHINE	48	105256	1/4 STD FLAT WASHER
12	B6172-12	NUT, JAM M12	49	363372	SAFETY MODULE - WB
13	453506	ROLLER, SPEED CONTROL	50	452170-1	HANDLE, PARK BRAKE - BLK
14	B5787-612	FLANGE SCREW M6X12	51	452185-2	COVER, PARK BRAKE - RED
15	2808005	BLADE SWITCH	52	453509-2	PANEL, BRAKE MOUNT - RED
16	5208103	NUT RACK	53	523034	PARK SWITCH
17	623215	GROMMET	54	5208103	NUT RACK
18	453508	SPRING, SPEED CONTROL	55	100278	5/16-18 X 2-1/4 HHCS
19	453475	BUSHING, SPEED LEVER	56	453404	SPACER, LEVER MOUNT
20	452169-1	HANDLE, CONSOLE - BLK	57	453471	ROD, BRAKE CONNECTING
21	109001	5/16-18 WHIZLOCK NUT	58	3603012	PIN
22	104257	3/8-16 HEX NYLOC NUT	59	B6182-8	NUT, NYLOC M8
23	104256	5/16-18 HEX NYLOC NUT	60	363165	#3 HAIRPIN COTTER
24	100296	3/8-16 X 2 HHCS	61	100273	5/16-18X1 HHCS
25	105257	5/16 SAE FLAT WASHER	62	453584	SPRING, BRAKE DETENT
26	100271	5/16-18 X 3/4 HHCS	63	453577	LEVER, BRAKE DETENT
27	322020-1	LOCK,LH HYDRO - BLK	64	453585	SPRING, OPC PALM LEVER
28	B879-530	SPRING PIN 5X30	65	453579	HOUSING, OPC SWITCH
29	3206010	TORSION SPRING, LEFT	66	453588	MODULE, OPC SWITCH
30	B879-38	PIN, 3 X 8 ROLL	67	B6172-8	NUT, JAM M8
31	3206033	BUSHING	68	B6172-8L	NUT, JAM M8L
32	454117	LEVER, TRACTION SPEED	69	453575	ROD,SPEED CONTROL
33	363073	TRACTION LEVER PIN	70	2836005	TURNBUCKLE,M8X1.25
34	363219	3/16 PALNUT	71	453590	BEARING,M8L ROD-END
35	106340	5/16 X 1 ROLL PIN	72	SIBJK8T	ROD END BEARING
36	3206011	TORSION SPRING,RT	73	322021-1	LOCK,RH HYDRO - BLK
37	100013	5/16-18X1-3/4 HHTB	74	454144	LINK ASM, SPEED CONTROL

YOKE CASTER COMPLETE

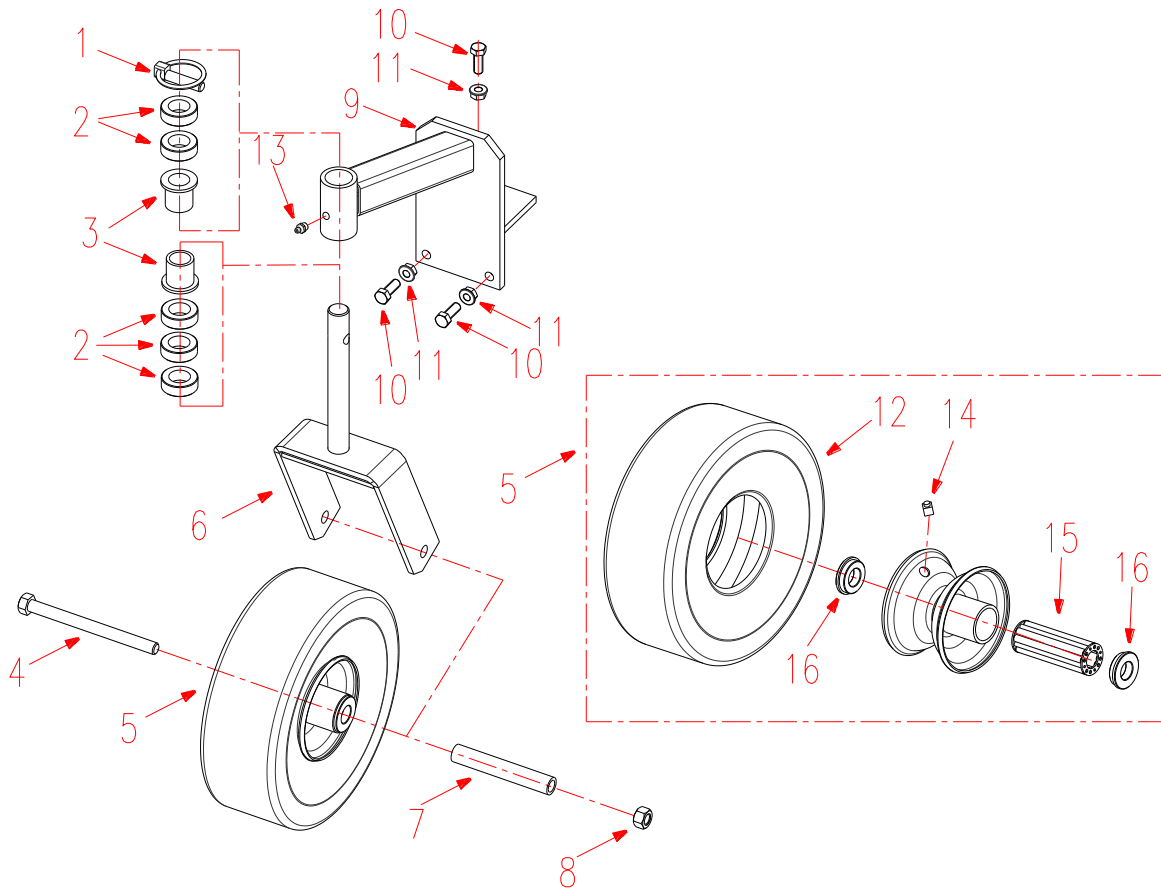

ITEMS	PART NO.	DESCRIPTION
1	109020	7/16 X 1-3/4 QUICK PIN HD
2	363006	10" CASTER SPACER
3	363007	FLANGE BEARING
4	100339	1/2-13 X 6 HHCS
5	363311	10" CASTER WHEEL
6	362081	YOKE-STRUT WLDMT
7	363307	AXLE TUBE
8	104259	1/2-13 HEX NYLOC NUT
9	362007	CASTER SUPPORT W/ BUSHING
10	100292	3/8-16 X 1 HHCS
11	109007	3/8-16 WHIZLOCK NUT
12	363360	TIRE Tube
13	111001	GREASE ZEAK
14	111005	GREASE ZEAK
15	423200	WHEEL HUB BEARING
16	423201	BEARING RETAINER

FIVE GALLON FUEL TANK ASM

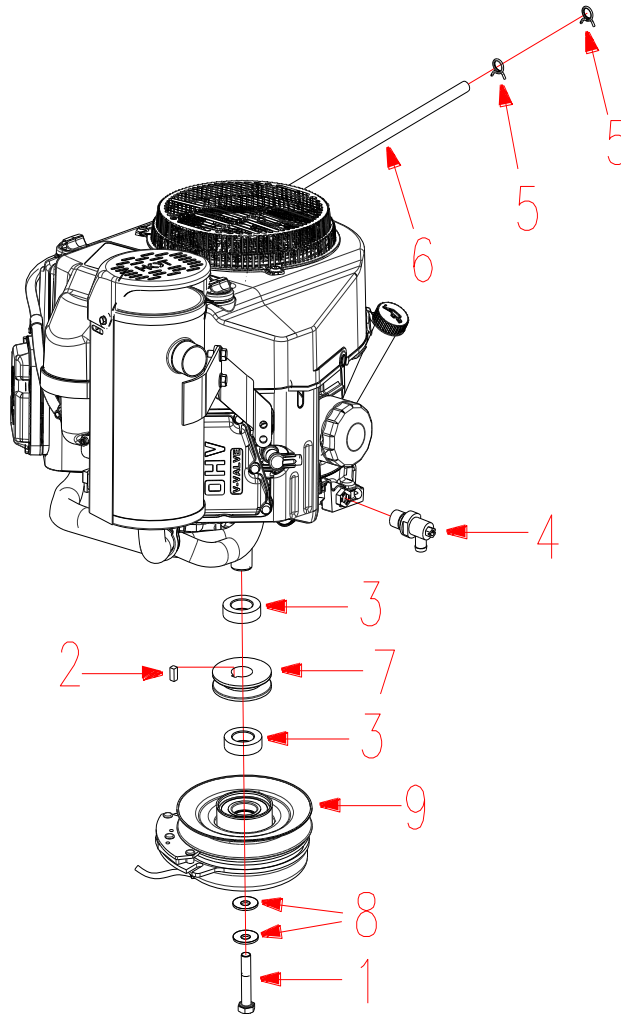

ITEMS	PART NO.	DESCRIPTION
1	100535	7/16-20 X 2-1/2 HHCS
2	107257	1/4 X 1/4 X 5/8 MACH KEY
3	583110	PULLEY SPACER
4	343146	90 DEGREE DRAIN
5	363098	CLAMP, FUEL LINE 1/4 ID
6	363099	LONG FUEL LINE
7	453071	TRANSMISSION PULLEY
8	423069	SPRING DISC. - 7/16
9	453478	CLUTCH, ELECTRIC BRAKE

FIVE GALLON FUEL TANK ASM

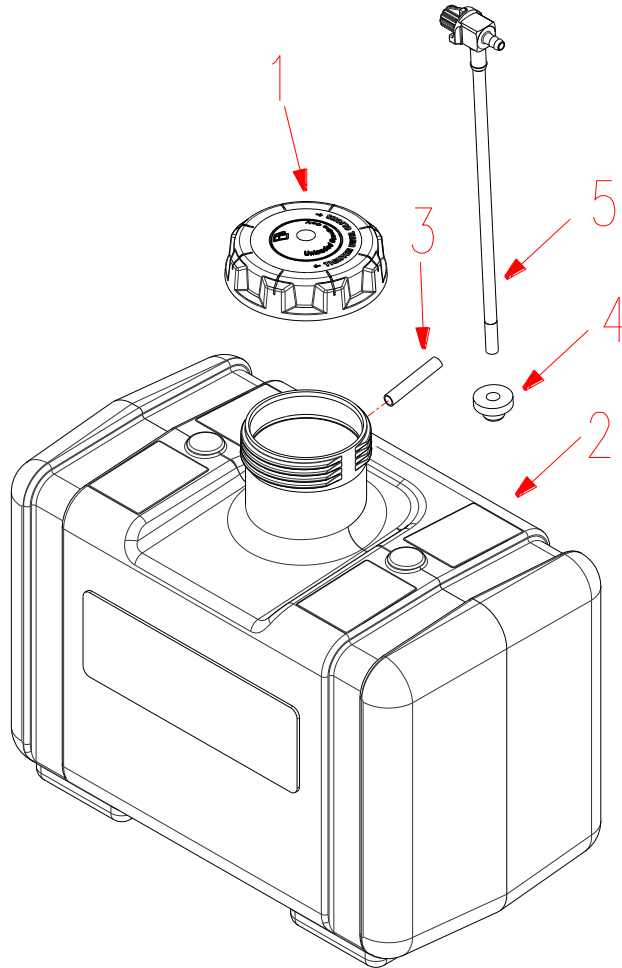

ITEM	PART NO.	DESCRIPTION
1	5204019	Fuel Tank Cap
2	363410	Fuel Tank, ASM.
3	4805004	VENT VALVE
4	533125	GROMMET
5	363418	FUEL VALVE

GRP, WHEEL AND HUB

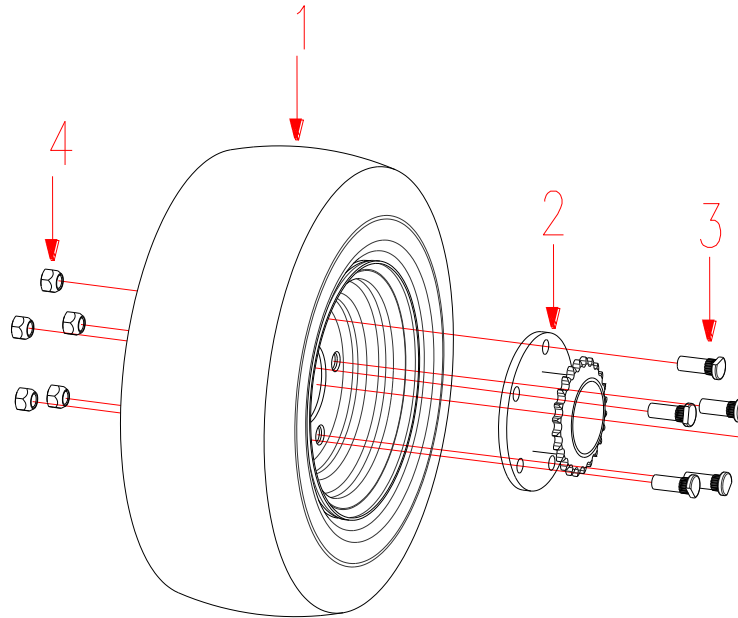

ITEMS	PART NO.	DESCRIPTION
1	453065	WHEEL & TIRE
2	452158	HUB ASM, 5-BOLT W/STUDS
3	103031-1	1/2-20X1-3/8 WHEEL STUD
4	103023	1/2-20 X 60 T LUG NUT

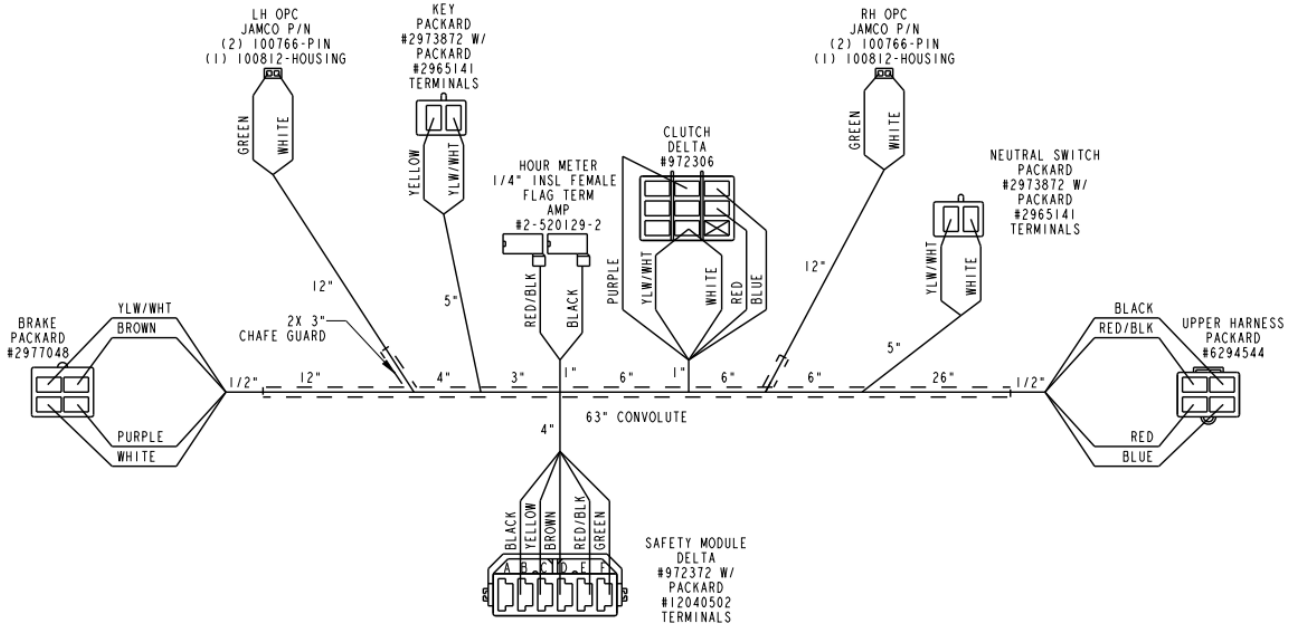

1

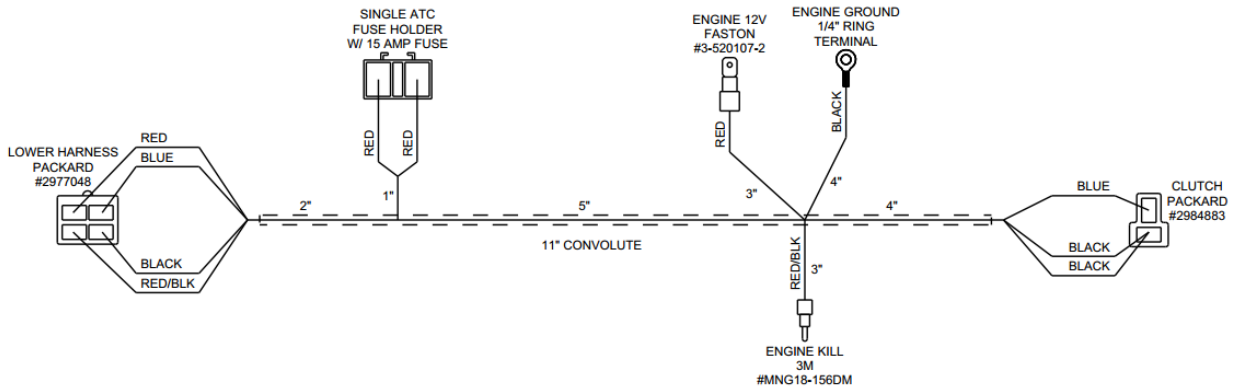









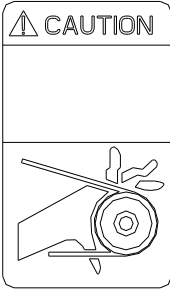

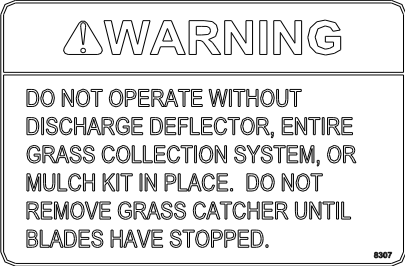
2

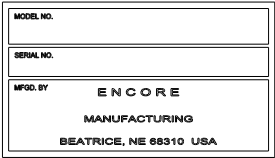
ITEMS	PART NO.	DESCRIPTION
1	323050	HARNESS, H-DRIVE
2	323051	HARNESS, ENGINE WIRE

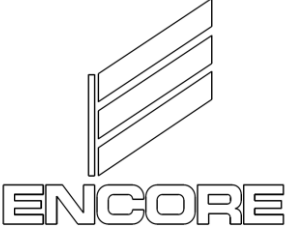
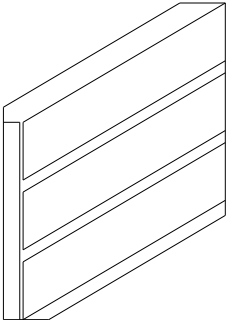
DECAL

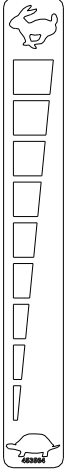
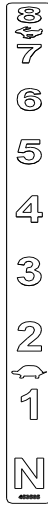
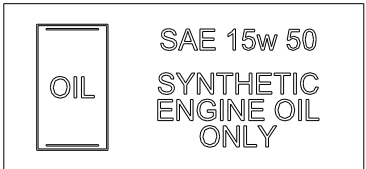
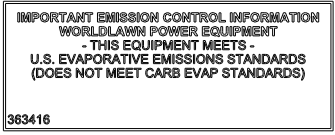
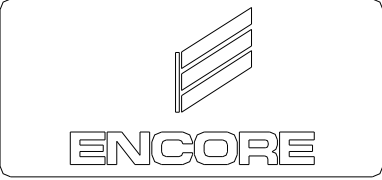
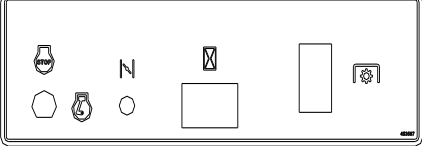

 <p>1</p>	 <p>2</p>	 <p>3</p>	
 <p>4</p>	 <p>5</p>	 <p>6</p>	
 <p>7</p>	 <p>10</p>	 <p>11</p>	
 <p>8</p>	 <p>18</p>		
 <p>9</p>			
 <p>12</p>	 <p>13</p>	 <p>14</p>	 <p>16</p>
		 <p>15</p>	 <p>17</p>



DECAL

ITEMS	PART NO.	DESCRIPTION	ITEMS	PART NO.	DESCRIPTION
1	8008	DECAL, CAUTION, GUARDING LG	10	453570	DECAL, 10" ENCORE LOGO
2	363038	CAUTION INST. LABEL	11	363362	ENCORE LOGO
3	8307	DECAL, DISCHARGE WARNING	12	453564	DECAL, THROTTLE
4	363023	DANGER DECAL, HANDS AND FEET	13	453565	DECAL,GROUND SPEED
5	363026	SERIAL NO. PLATE	14	423354	OIL DECAL - SYN.
6	8303	DECAL, CAUTION, GUARDING SM	15	453563	DECAL, EN HANDLE
7	363243	SMALL "ENCORE" LABEL	16	363416	EPA LABEL - WB
8	453568	DECAL,PARK	17	453567	DECAL, CONTROL CONSOLE
9	363356	HYDRO PRO 36	18	483075	HYDRO PRO-48 DECAL

