

**X-TREME™**

**52K26X**

**PARTS  
MANUAL**

# Table of Contents

■ QUICK REFERENCE GUIDE FOR 52K26X.....	A - 1
■ DECK COMPONENTS .....	B - 1
■ DECK LIFT COMPONENTS .....	C - 1
■ FRAME COMPONENTS.....	D - 1
■ DRIVE COMPONENTS .....	E - 1
■ CONTROL COMPONENTS	
LINKAGE PARTS.....	F - 1
RIGHT HAND CONTROL BOX PARTS .....	F - 3
LEFT HAND CONTROL BOX PARTS .....	F - 5
■ BRAKE COMPONENTS	
RIGHT HAND SIDE .....	G - 1
LEFT HAND SIDE.....	G - 3
■ HYDRO COMPONENTS .....	H - 1
■ FUEL COMPONENTS .....	I - 1
■ ELECTRICAL SCHEMATICS.....	J - 1
■ DECAL LIST.....	K - 1
■ BLANK NOTE PAGES .....	L - 1

**Engine**

Kawasaki V-Twin FX730V-S12

**Blades**

823004 18" Blade  
 363293 18" Low Lift Blade  
 823353 18" Mulch Blade  
 523449 18" Super Hi-Lift Blade

**Belts**

523472 Blade Drive Belt  
 533088 Pump Drive Belt

**Tires**

533024 Wheel/Tire Asm  
 533069 Drive Tire 23x9.5x12  
 583058 Rim W/Valvestem  
 523280 Front Caster Complete  
 123049 Tire 13x5x6 Front Caster

**Spindles**

583106 Spindle Asm Complete  
 583111 Housing  
 363350 Bearing  
 583112 Shaft  
 583113 Bearing Spacer Tube

**Throttle**

363352

**Choke**

523037

**Electrical Components**

423027 Ignition Switch  
 422150 Starter Relay  
 523034 Park Brake Switch  
 593041 Neutral Switch  
 523031 PTO Switch  
 523030 Seat Switch  
 523283 Hour Meter  
 533176 Wire Harness  
 423030 Safety Module

**Clutch**

603078

**Transmission**

583325 Wheel Motor TJ0230US080AAAJ  
 533153 Hydro Pump W/RTN  
 423361 Hydro Filter

**Torque Specs**

50 ft-lbs Clutch Bolt  
 60 ft-lbs Blade Bolt  
 90 ft-lbs Nut on Top of Spindle  
 175-200 ft-lbs Wheel Motor Axle Nut

**Pulleys**

423231 Pump Drive Pulley  
 523328 Tensioner Pulley-Pump Belt  
 533052 Pump Pulley  
 533114 Tensioner Pulley-Blade Drive Belt  
 373068 Stationary Idler Pulley-Deck  
 523496 Pulley-Blade Spindle

**Front Caster Bearings**

533086 Bearings

**Brakes**

592094 Wheel Hub-Shoe Brake  
 533032 Drum Brake Link  
 423310 Brake Drum  
 423276 Brake Shoe  
 423281 Brake Spring

**Seat**

583077 Seat Complete W/Tracks  
 583089 Seat Cushion  
 583090 Back Cushion  
 593097 Molded Arm Rest

**Muffler**

533151

**Gasket**

483098

**Seal Kit** 583520**Seal Kit** 453146

\*\*\*Synthetic Hydro Oil Capacity Approx 2.7 qts.

# X-TREME<sup>52</sup> Deck Components

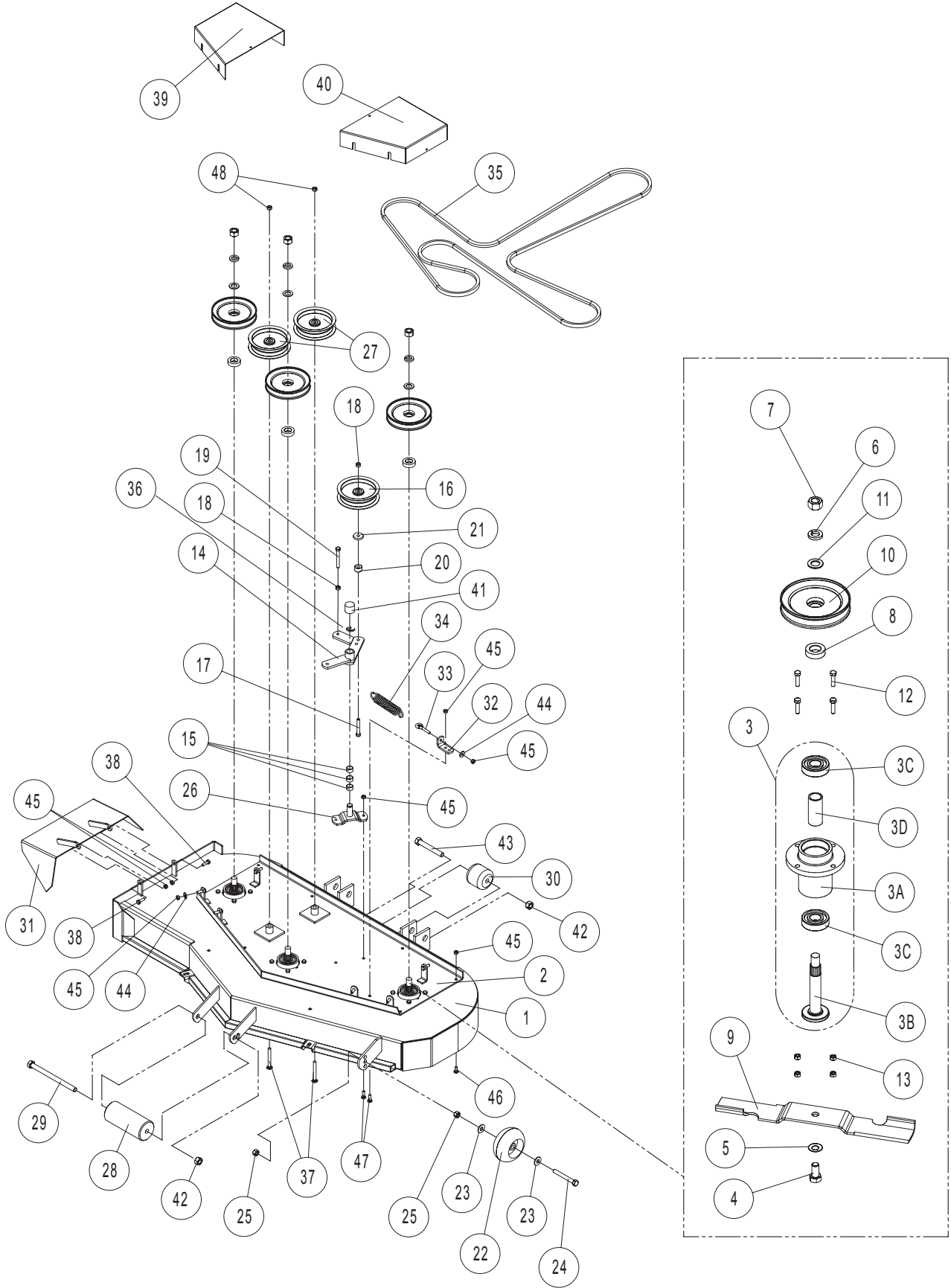



# Deck Components

#	PART NO.	QTY.	DESCRIPTION
1	532004	1	X52 MOWER DECK
2	532006	1	SUB PLATE X52
3	583106	3	BLADE SPINDLE ASSY
3A	583111	3	SPINDLE HOUSING
3B	583112	3	SPINDLE SHAFT
3C	363350	6	BEARING - BLADE SPINDLE
3D	583113	3	BEARING SPACER TUBE
4	100355	3	5/8-11 X 1-1/4 HHCS
5	583108	3	5/8 DISC SPRING WASHER
6	105010	3	3/4 LOCK WASHER
7	104511	3	3/4-16 HEX NUT
8	583110	3	PULLEY SPACER
9	823004	3	18" HI LIFT BLADE
10	523496	3	6.25" HEX PULLEY
11	823015	3	WASHER
12	100274	12	5/16-18 X 1-1/4 HHCS
13	104256	12	5/16-18 NYLOC NUT
14	522164	1	Z-DECK TENSIONER W/ BSHNGS
15	363089	3	BRONZE BUSHINGS
16	533114	1	ENGAGEMENT IDLER
17	100298	1	3/8-16 X 2-1/2 HHCS
18	109007	2	3/8-16 WHIZ LOCK NUT
19	100300	1	3/8-16 X 3 HHCS
20	823309	1	FRAME SPACER
21	373089	1	RETAINING WASHER
22	423023	1	DECK ROLLER
23	105264	2	1/2 STD FLAT WASHER
24	100335	1	1/2-13 X 4 HHCS
25	104509	2	1/2-13 HEX NUT
26	522104	1	OFFSET PIVOT
27	373068	2	ENGAGEMENT IDLER
28	603023	1	FRONT ANT-SCALP ROLLER
29	100351	1	5/8-11 X 8-1/2 HHCS
30	523084	1	REAR DECK ROLLER
31	532073	1	PLASTIC CHUTE ASM
32	523094	1	SPRING MOUNT
33	363080	1	RIGHT EYEBOLT
34	523327	1	FLOATING IDLER SPRING
35	523472	1	DECK DRIVE BELT
36	108509	1	3/4 E-RING
37	107506	2	3/8-16 X 3-1/4 CARRIAGE BOLT
38	100273	2	5/16-18 X 1 HHCS
39	532018	1	X52 RH BELT COVER



## DECK COMPONENTS

#	PART NO.	QTY	DESCRIPTION
40	532020	1	X52 LH BELT COVER
41	103009	1	CAPLUG 1-1/4
42	104261	2	5/8-11 HEX NUT
43	100346	1	5/8-11 X 4-1/2 HHCS
44	105258	2	5/16 STD FLAT WASHER
45	104256	7	5/16-18 NYLOC NUT
46	107503	1	5/16-18 X 3/4 CARR. HEAD
47	107509	2	5/16-18 X 1 CARR. BOLT
48	109007	2	3/8-16 WHIZ LOCK NUT

### ANTI-SCALP ROLLER KIT 52" XTREME KIT PART # - 532074

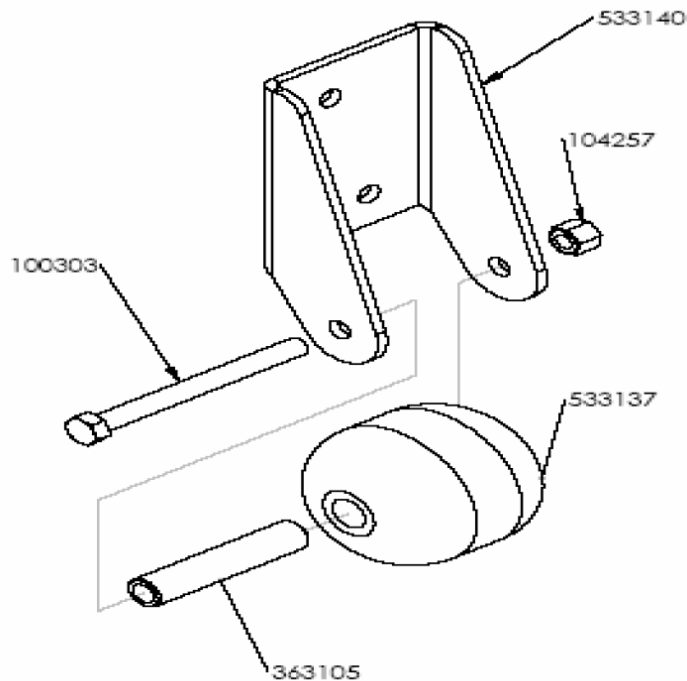

PART NO.	DESCRIPTION	QTY
100303	3/8-16 X 4 HHCS	1
100524	3/8-24 X 1 HHCS - <b>NOT PICTURED</b>	3
104257	3/8-16 HEX NYLOC NUT	1
105006	3/8 LOCKWASHER - <b>NOT PICTURED</b>	3
363105	IDLER BUSHING	1
533137	ROLLER - X52 DECK	1
533140	ROLLER MOUNT	1
533142	ROLLER MT STRAP - <b>NOT PICTURED</b>	1

# X-TREME<sup>52</sup> Deck Lift Components

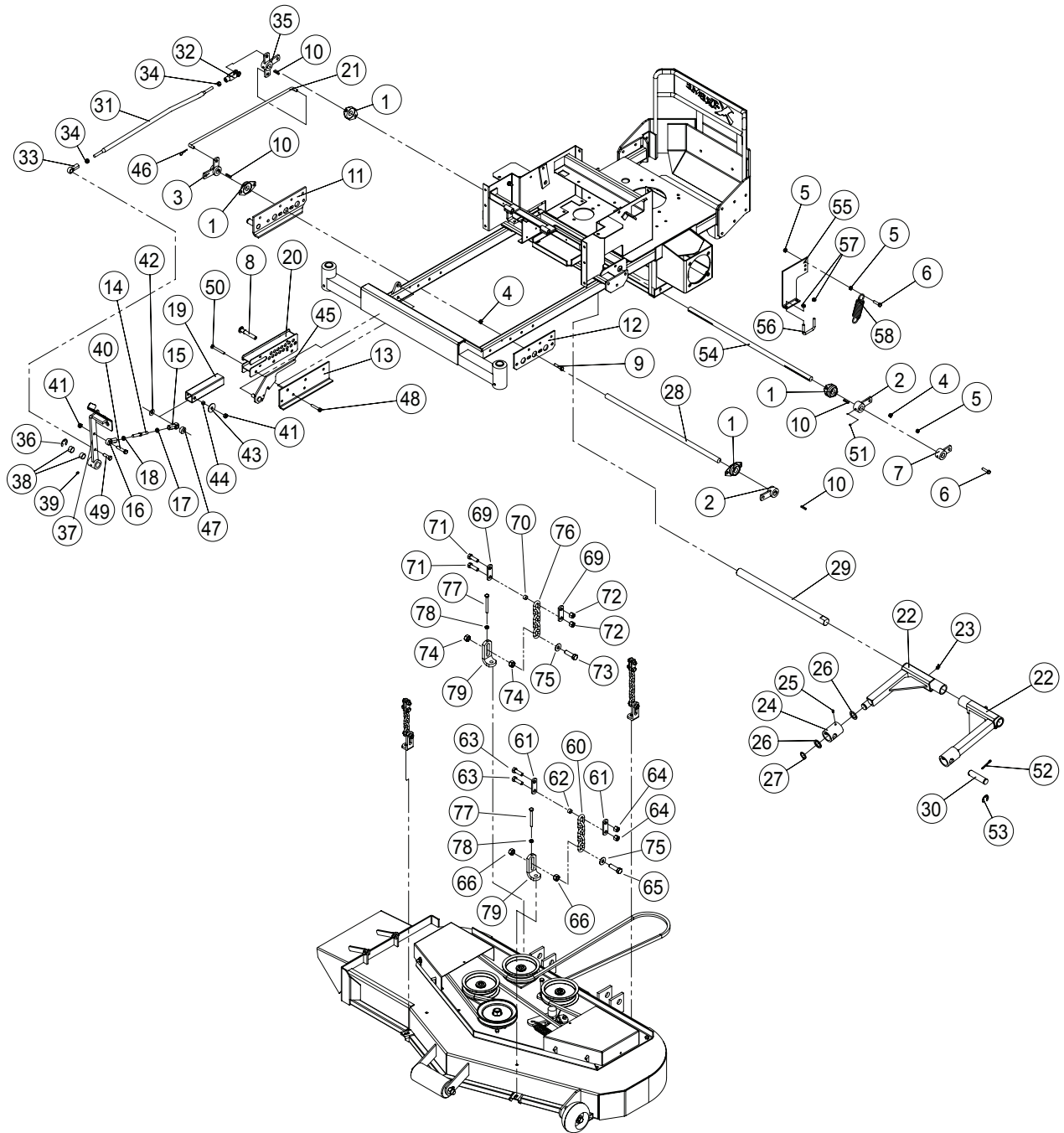



# Deck Lift Components

#	PART NO.	QTY.	DESCRIPTION
1	423140	4	3/4 2 BOLT BEARING
2	422041	2	DECK LIFT ARM
3	422043	1	DECK LIFT CRANK
4	104256	2	5/16 NYLOCK NUT
5	109001	3	5/16-18 WHIZLOCK NUT
6	100274	2	5/16-18 X 1-1/4 HHCS
7	422056	1	SPRING ASSIST ARM
8	109036	1	DECK HEIGHT PIN
9	100275	1	5/16-18 X 1 1/2 HHCS
10	107255	4	3/16 X 3/16 X 1 MACHINE KEY
11	422128	1	LIFT MOUNT
12	423344	1	LH LIFT MOUNT
13	423322	1	HEIGHT GAGE MOUNT
14	343158	1	FOOT PEDAL LINK
15	523104	1	ROD END RH 3/8
16	343160	1	ROD END LHF 3/8
17	104754	1	3/8-24 HEX JAM NUT
18	109037	1	3/8-24 LH HEX JAM NUT
19	343093	1	DECK HEIGHT TUBE
20	342016	1	HEIGHT CONTROL
21	523474	1	DECK LIFT ROD
22	532008	1	DECK ARM WELDMENT
23	111008	2	1/4-28 TAPER THREAD - 90 DEGREE ZERK
24	823074	1	DECK ARM SWIVEL
25	111004	1	1/4-28 ZERK
26	823015	2	DECK ARM WASHER RAW
27	108502	1	1.0 EXTERNAL SNAP RING
28	533010	1	LIFT SHAFT- FRONT
29	823050	1	DECK ARM SHAFT
30	823333	2	DECK ATTACH PIN
31	533060	1	DECK LIFT ROD ( SEE NOTE 1 BEFORE ORDERING )
32	363192	1	LARGE YOKE (3/8")
32A	533083	1	CLEVIS END - 1/2"
33	423353	1	OFFSET ROD END (3/8")
33A	533084	1	ROD END - 1/2"
34	109008	2	3/8-24 WHIZLOCK NUT
34A	104755	2	1/2-20 JAM NUT
35	532036	1	DECK LIFT HUB
36	108509	1	E-RING 3/4 DIA.
37	532076	1	DECK LIFT PEDAL
38	363089	2	BRONZE BUSHINGS
39	111004	1	1/4-28 ZERK
40	100295	1	3/8-16 X 1-3/4 HHCS



# Deck Lift Components

#	PART NO.	QTY.	DESCRIPTION
41	104257	2	3/8-16 NYLOCK NUT
42	105260	1	3/8 STANDARD FLAT WASHER
43	483019	1	RT. HAND IDLER WASHER
44	363174	1	EYE BOLT SPACER
45	532032	1	LIFT LOCK WELDMENT
46	363165	1	#3 HAIRPIN COTTOR
47	483017	1	RH IDLER SPACER
48	100276	1	5/16-18 X 1-3/4 HHCS
49	100293	1	3/8-16 x 1 1/4 HHCS
50	100279	1	5/16-18 X 2-1/2 HHCS
51	103292	1	1/4-28 SETSCREW
52	106778	2	3/16 X 1-1/2 COTTER PIN
53	108510	2	7/8 E-RING
54	423096	1	REAR DECK LIFT SHAFT
55	423382	1	SPRING MOUNT
56	523375	1	U-BOLT SQ. 2"
57	104256	2	5/16-18 NYLOCK
58	523327	1	FLOATING IDLER SPRING
59	423358	1	DECK LIFT ANGLE
60	423359	1	FRONT CHAIN
61	423356	2	LIFT CHAIN LINK
62	363174	1	EYE BOLT SPACER
63	100293	2	3/8-16 x 1 1/4 HHCS
64	104257	2	3/8-16 NYLOCK NUT
65	100311	1	7/16-14 X 1-1/2
66	109027	2	7/16-14 WHIZLOCK NUT
67	105260	1	3/8 STANDARD FLAT WASHER
68	423358	1	DECK LIFT ANGLE
69	423356	2	LIFT CHAIN LINK
70	363174	1	EYE BOLT SPACER
71	100293	2	3/8-16 x 1 1/4 HHCS
72	104257	2	3/8-16 NYLOCK NUT
73	100311	1	7/16-14 X 1-1/2
74	109027	2	7/16-14 WHIZLOCK NUT
75	105260	1	3/8 STANDARD FLAT WASHER
76	423360	1	REAR CHAIN
77	100008	4	1/4-20 X 2 HHCS
78	104758	4	1/4-20 HEX JAM NUT
79	533112	4	ADJUSTABLE CHAIN MOUNT

**NOTE:**

- 1 UNITS WITH SERIAL NUMBER BELOW 50242, WILL ALSO NEED TO ORDER ITEM 32A (533083), ITEM 33A (533084), & 2 OF ITEM 34A (104755)

# X-TREME<sup>52</sup> Frame Components

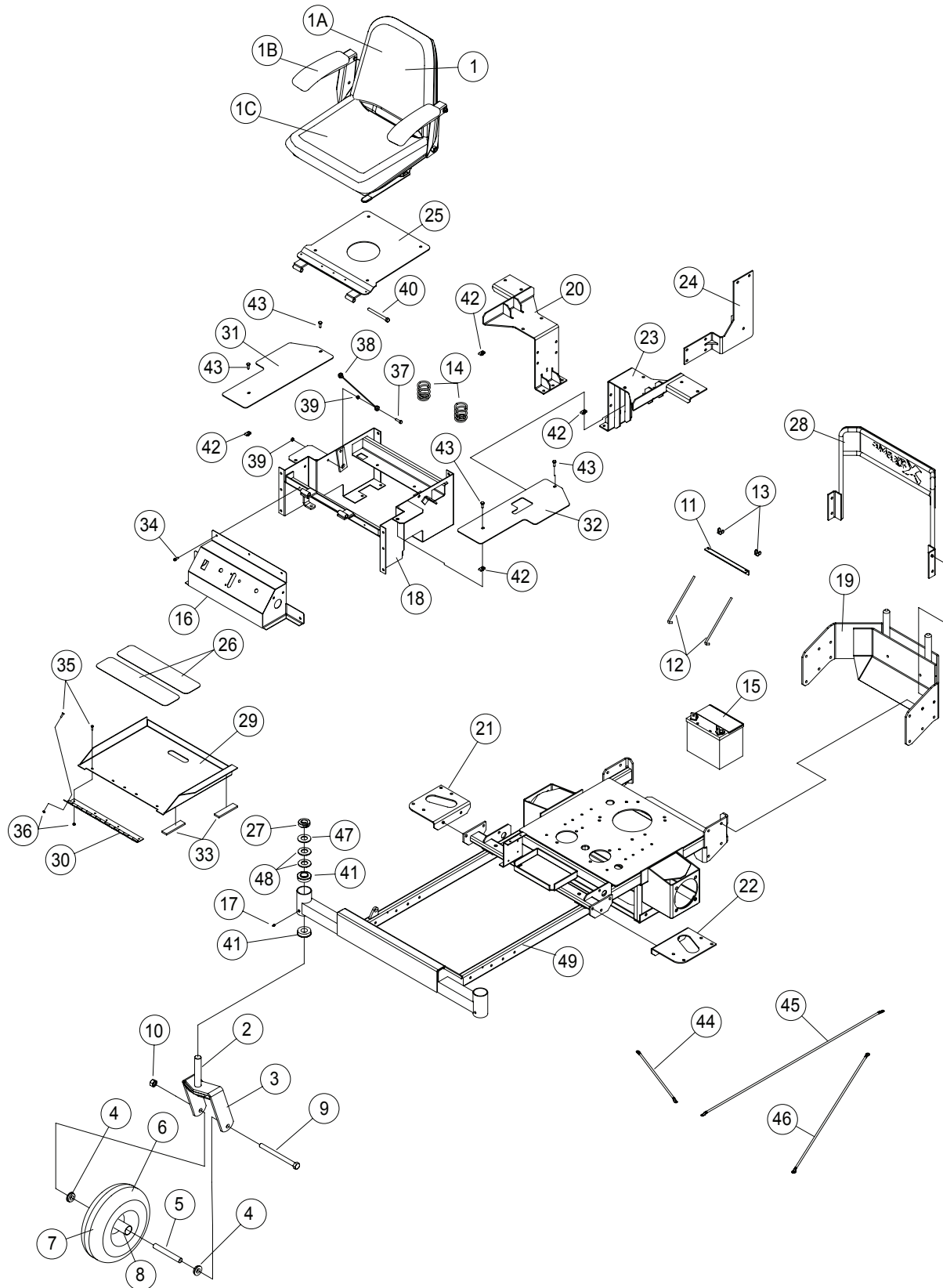



# Frame Components

#	PART NO.	QTY.	DESCRIPTION
1	583077	1	SEAT LT. GREY W/ TRACK
1A	533184	--	BACK SEAT CUSHION
1B	593097	--	MOLDED ARM REST
1C	533185	--	SEAT CUSHION
2	-----	--	N/A
3	522097	1	13" STRUT WELDMENT
4	533086	2	BEARING-FRONT WHEEL 3/4 BALL
5	523098	1	LARGE AXLE TUBE
6	523280	1	FRONT WHEEL COMPLETE
7	123049	1	TIRE (13 X 5 X 6)
8	533078	1	FRONT CASTER RIM
9	100349	1	5/8-11 X 7-1/2 HHCS
10	104261	1	5/8-11 HEX NUT
11	423011	1	HOLD DOWN ANGLE
12	423172	2	BATTERY HOLD DOWN RODS
13	109012	2	1/4 WING NUT
14	523278	2	SEAT SPRING
15	423142	1	BATTERY, U1-9
16	422148	1	CONTROL PANEL - Z
17	111001	1	1/8 NPT STRAIGHT ZERK
18	532012	1	SEAT FRAME WLDMNT - PNTD
19	532016	1	REAR GUARD
20	532022	1	RH REAR TANK MOUNT
21	533042	1	FRONT TANK PLATE RH
22	533044	1	FRONT TANK PLATE LH
23	532024	1	LH REAR TANK MOUNT
24	422136	1	OIL TANK MOUNT
25	422132	1	SEAT PLATE
26	343110	3	STEP TREAD - Z34
27	363145	2	1" CLAMP COLLAR
28	532010	1	AC GUARD WELDMENT
29	533026	1	FOOT PLATE
30	523105	1	HINGE
31	533046	1	RH SEAT PANEL
32	533048	1	LH SEAT PANEL
33	363201	2	GAS TANK PAD
34	102000	1	SELF TAPPING SCREW #12-24 X 5/8
35	101039	2	#10-24 X 5/8 PAN HD. SCREW
36	104252	2	#10 NYLOCK NUT
37	100004	1	1/4-20 x 1 HHCS
38	523044	1	SEAT CABLE
39	109000	2	1/4-20 WHIZ LOCK NUT
40	100303	1	3/8-16 X 4 HHCS



## Frame Components

#	PART NO.	QTY	DESCRIPTION
41	363187	4	7/8 FLANGE BEARING
42	109015	4	1/4-20 NUT CLIP
43	100252	4	1/4-20 X 3/4 HHCS
44	423116	1	POSITIVE CABLE – SHORT
45	423117	1	POSITIVE CABLE – LONG
46	423118	1	NEGATIVE CABLE
47	583171	2	CASTER WASHER
48	105501	4	WAVY WASHER
49	532002	1	MAINFRAME WLDMT, PNTD

# X-TREME<sup>52</sup> Drive Components

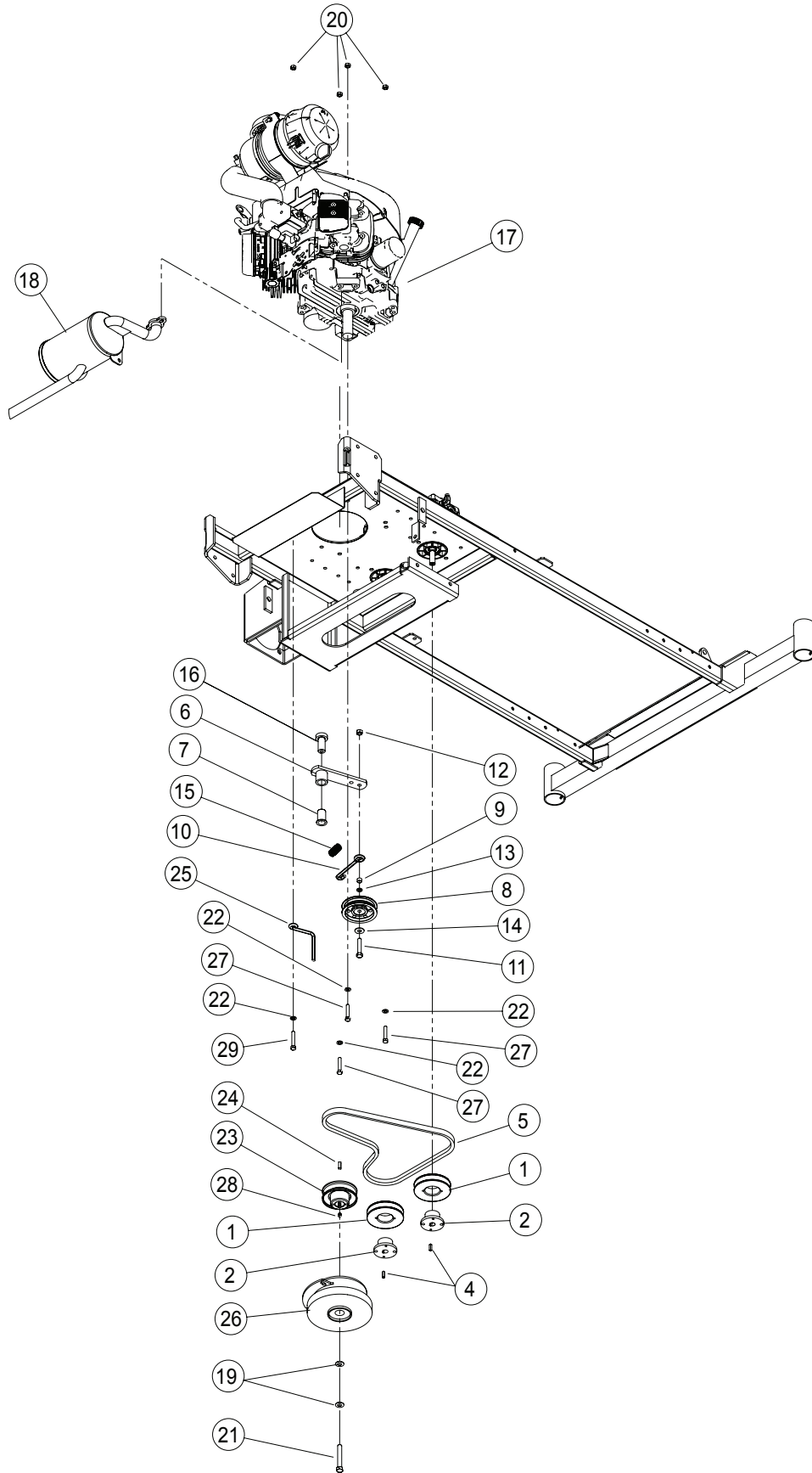



# Drive Components

#	PART NO.	QTY.	DESCRIPTION
1	533052	2	PUMP PULLEY
2	423178	2	15MM TAPER HUB
3	453074	4	90° ADAPTER
4	453102	2	PUMP KEY
5	423272	1	PUMP DRIVE BELT
6	422025	1	TENSIONER W/ BUSHING
7	523111	1	3/4 PLASTIC BUSHING
8	523328	1	FLAT IDLER
9	363174	1	EYE BOLT SPACER
10	423122	1	PUMP TENSION ROD
11	100296	1	3/8-16 X 2 HHCS
12	109007	1	3/8-16 WHIZ LOCK NUT
13	105005	1	3/8 LOCK WASHER
14	105260	1	3/8 STANDARD FLAT WASHER
15	553007	1	IDLER SPRING
16	423175	1	IDLER PIVOT
17	N/A	1	ENGINE
18	533151	1	MUFFLER - 26 KAW FX
19	423069	2	7/16 DISC SPRING WASHER
20	104256	4	5/16-18 NYLOCK
21	100536	1	7/16-20 X 3 HHCS
22	363226	4	5/16 DISC SPRING WASHER
23	423231	1	DRIVE PULLEY – PUMP
24	107258	1	1/4 X 1/4 X 3/4 MACH. KEY
25	373070	1	BELT GUIDE - LONG
26	603078	1	ELECTRIC CLUTCH – 200 FT LBS
27	100276	3	5/16-18 X 1-3/4 HHCS
28	103293	1	5/16-18 SET SCREW
29	100277	1	5/16-18 X 2 HHCS
	603083	1	CLUTCH ADAPTER HARNESS (NOT SHOWN)

## Control Components - Linkage

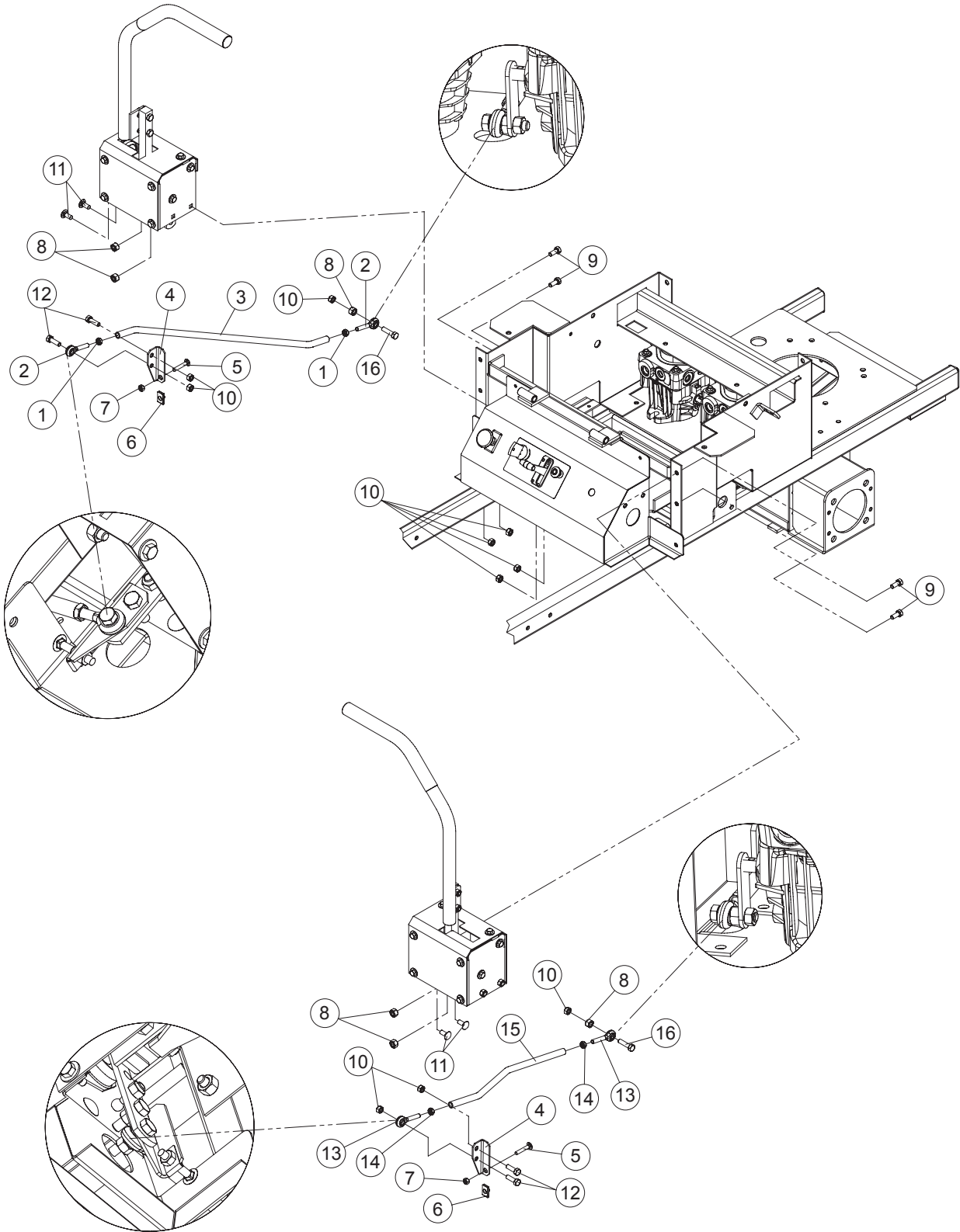



## Control Components - Linkage

#	PART NO.	QTY.	DESCRIPTION
1	104752	2	5/16-24 JAM NUT
2	453082	2	5/16 ROD END
3	423318	1	CONTROL LINK - RH
4	423376	2	LEVER STOP ANGLE
5	107523	2	1/4-20 x 1-1/2 CARR HD BOLT
6	109015	2	1/4-20 NUT CLIP
7	109000	2	1/4-20 WHIZ LOCK NUT
8	104256	7	5/16 NYLOCK NUT
9	100271	4	5/16-18 X 3/4 HHCS
10	104256	10	5/16-18 WHIZLOCK
11	107503	4	5/16-18 X 3/4 CARR BOLT
12	100273	4	5/16-18 X 1 HHCS
13	453082	2	5/16 ROD END
14	104752	2	5/16-24 JAM NUT
15	423317	1	CONTROL LINK - LH
16	100274	2	5/16-18 X 1-1/4 HHCS

## Control Components - RH Handles

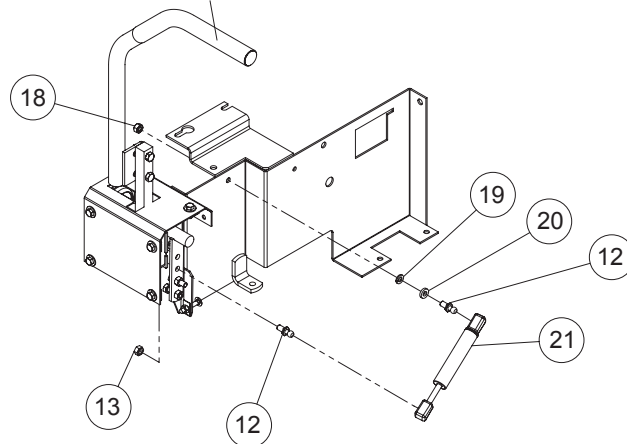
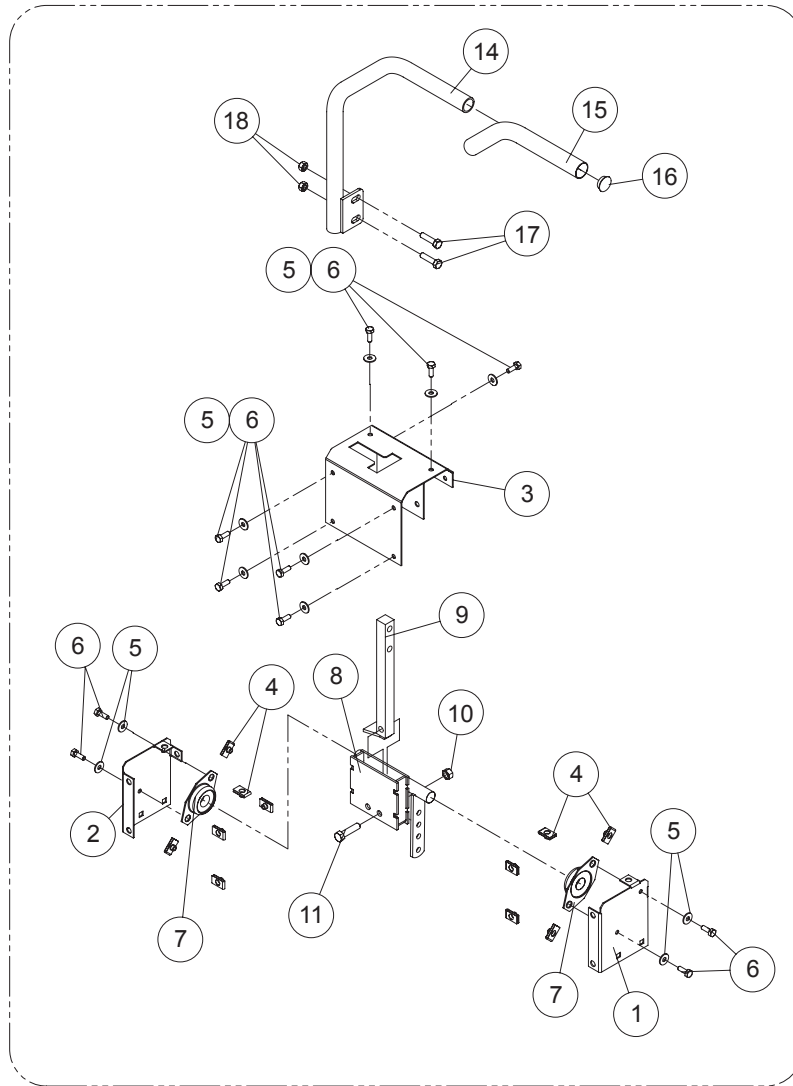



## Control Components - RH Handles

#	PART NO.	QTY.	DESCRIPTION
1	593028	1	LH CONTROL COVER
2	593026	1	RH CONTROL COVER
3	593022	1	RH CONTROL MOUNT
4	109015	11	1/4-20 NUT CLIP
5	105004	11	1/4 STD. LOCKWASHER
6	100252	11	1/4-20 X 3/4 HHCS
7	423140	2	3/4" 2 BOLT BEARING
8	592024	1	CONTROL PIVOT RIGHT
9	592060	1	HANDLE BAR w / STOP WELDMENT
10	104257	1	3/8-16 NYLOCK
11	100294	1	3/8-16 - 1-1/2 HHCS
12	823221	2	10 MM BALL STUD
13	104256	2	5/16-18 NYLOC NUT
14	592041	1	HANDLE RH W / GRIP
15	523032	1	HANDLE GRIP
16	523033	1	HANDLE PLUG
17	100274	2	5/16-18 X 1-1/4 HHCS
18	109001	2	5/16-18 WHIZLOCK NUT
19	105005	1	5/16 LOCKWASHER - HEAVY
20	253075	1	CABLE ANCHOR SPACER
21	823201	1	ANTI BUCK CYLINDER

## Control Components - LH Handles

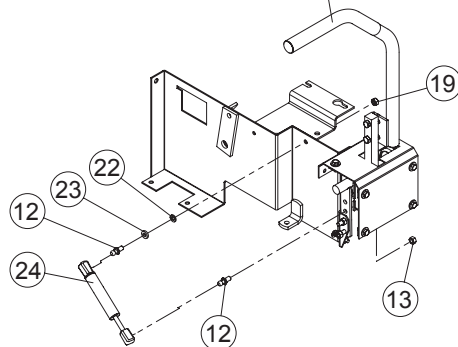
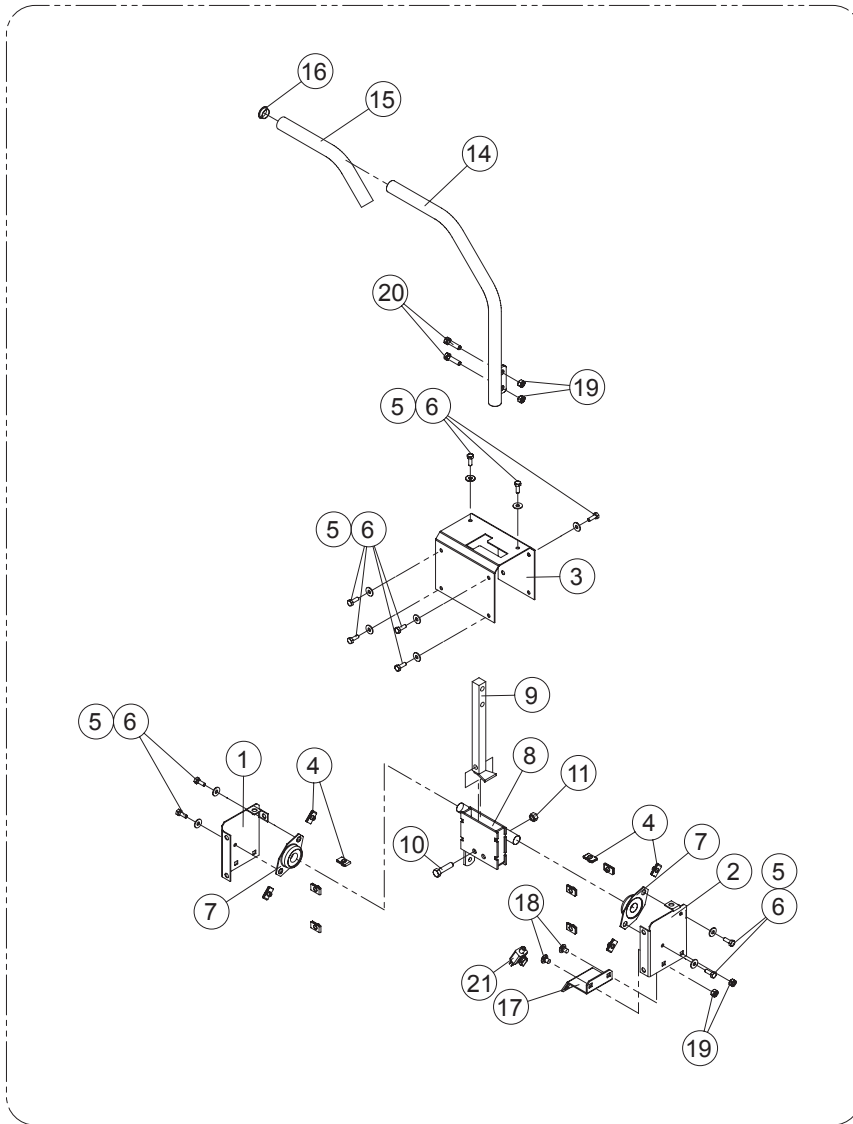



## Control Components - LH Handles

#	PART NO.	QTY.	DESCRIPTION
1	593026	1	RH CONTROL COVER
2	593028	1	LH CONTROL COVER
3	593024	1	LH CONTROL MOUNT
4	109015	11	1/4-20 NUT CLIP
5	105004	11	1/4 STD. LOCKWASHER
6	100252	11	1/4-20 X 3/4 HHCS
7	423140	2	3/4" 2 BOLT BEARING
8	592026	1	CONTROL PIVOT LEFT
9	592060	1	HANDLE BAR W / STOP WELDMNT
10	100294	1	3/8-16 - 1-1/2 HHCS
11	104257	1	3/8-16 NYLOCK
12	823221	2	10 MM BALL STUD
13	104256	2	5/16-18 NYLOC NUT
14	592042	1	HANDLE LH W / GRIP
15	523032	1	HANDLE GRIP
16	523033	1	HANDLE PLUG
17	593048	1	SWITCH MOUNT - NEUTRAL
18	107519	2	5/16-18 X 1/2 CARR BOLT
19	109001	4	5/16-18 WHIZLOCK NUT
20	100274	2	5/16-18 X 1-1/4 HHCS
21	593041	1	NEUTRAL SWITCH
22	105005	1	5/16 LOCKWASHER - HEAVY
23	253075	1	CABLE ANCHOR SPACER
24	823201	1	ANTI BUCK CYLINDER

## Brake Components - Right Hand

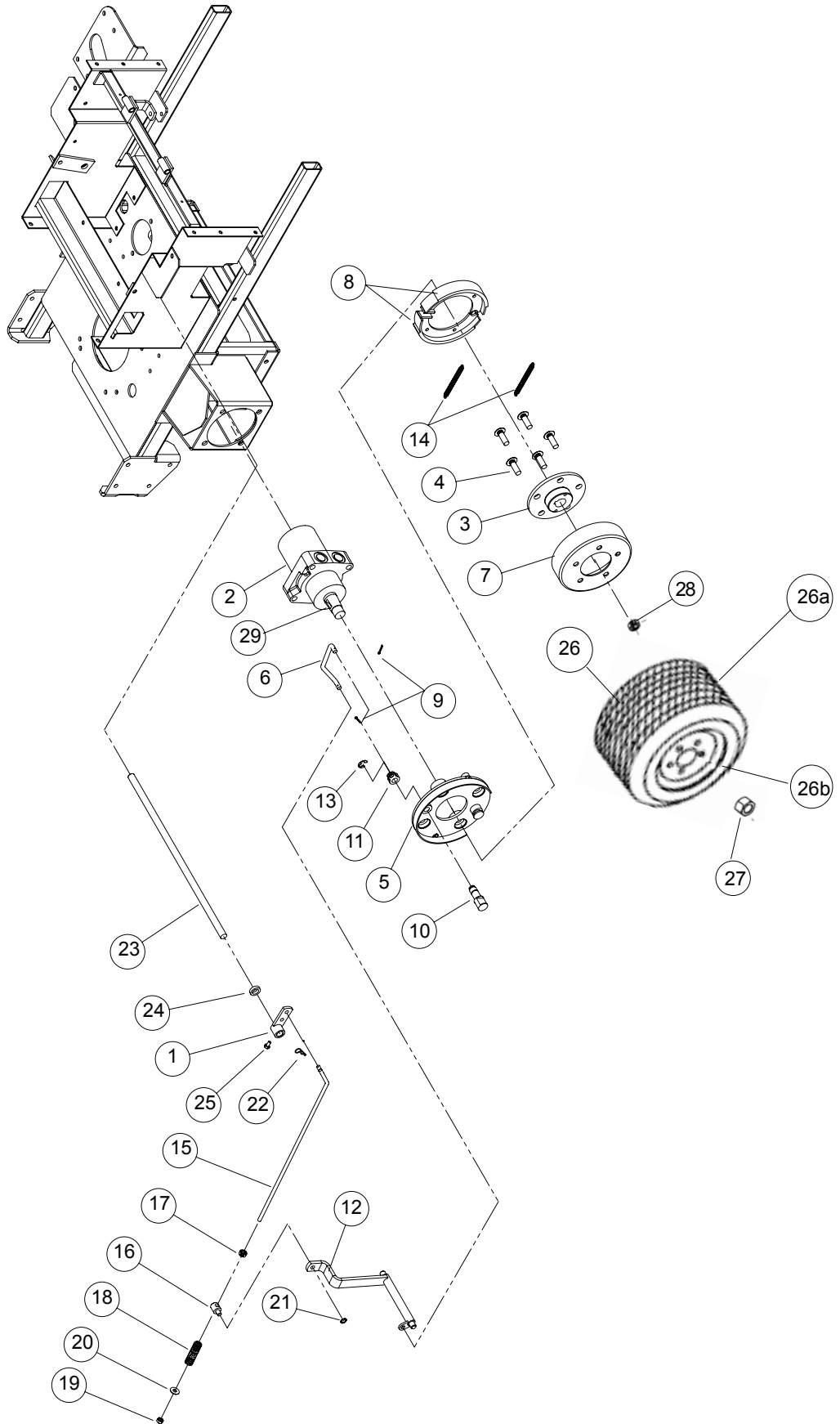



## Brake Components - Right Hand

#	PART NO.	QTY.	DESCRIPTION
1	422049	1	BRAKE CRANK WLDMNT - PLATED
2	583325	1	WHEEL MOTOR
3	592094	1	WHEEL HUB - SHOE BRAKE
4	103031	5	1/2-20 X 1 3/8 UNF PRESS IN STUD
5	592062	1	BACKPLATE - DRUM
6	533032	1	SHOE BRAKE LINK
7	423310	1	BRAKE DRUM - 180
8	423276	2	BRAKE SHOE
9	106753	2	3/32 X 3/4 COTTER PIN
10	423296	1	BRAKE CAM
11	423308	1	BRAKE CAM ARM
12	532025	1	BRAKE CONTROL - RH
13	108500	1	E-RING FOR 5/8 DIA.
14	423281	2	BRAKE SPRING
15	423128	1	PARK BRAKE LINK
16	423130	1	PARK BRAKE SWIVEL
17	523112	1	5/16 CLAMP COLLAR
18	523024	1	SPRING
19	104256	1	5/16 NYLOCK NUT
20	105258	1	5/16 FLAT WASHER
21	363177	1	3/8 PUSH NUT
22	363165	1	#3 HAIRPIN COTTER
23	423368	1	BRAKE CROSS SHAFT
24	363170	1	BLADE SPACER
25	100501	1	1/4-28 X 1/2 HHCS
26	533024	1	WHEEL/TIRE ASM 23 X 9.5 X 12
26a	533069	--	DRIVE TIRE 23 X 9.5 X 12
26b	583058	--	RIM W/VALVESTEM
27	103023	5	1/2-20 LUG NUT
28	593181	1	WHEEL MOTOR SHAFT NUT - TJ
29	107013	1	5/16 X 1 (1001) WOODRUFF KEY

## Brake Components - Left Hand

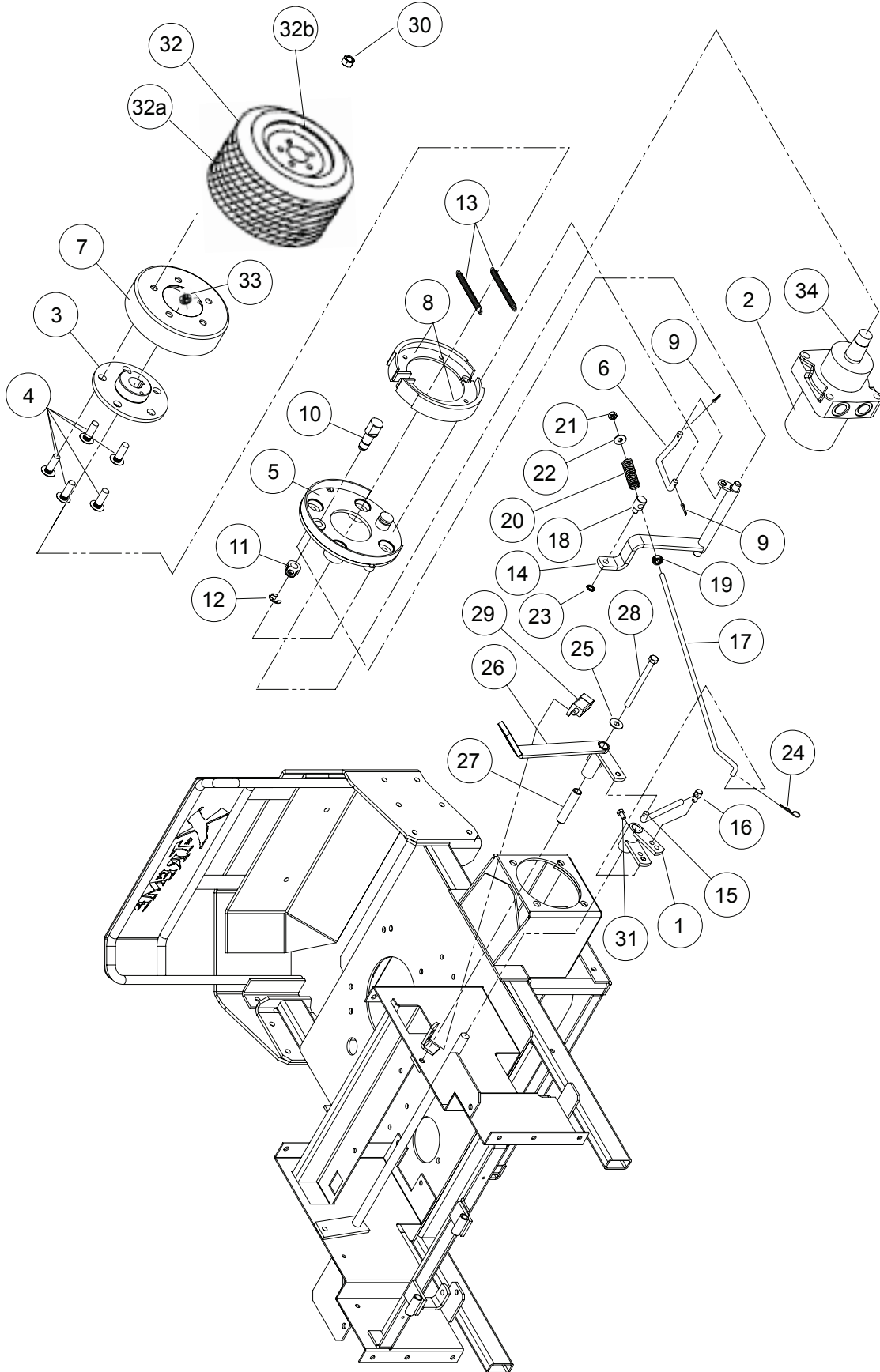



## Brake Components - Left Hand

#	PART NO.	QTY.	DESCRIPTION
1	422146	1	PARK BRAKE CRANK
2	583325	1	WHEEL MOTOR
3	592094	1	WHEEL HUB - SHOE BRAKE
4	103031	5	1/2-20 X 1 3/8 UNF PRESS IN STUD
5	592062	1	BACKPLATE - DRUM
6	533032	1	SHOE BRAKE LINK
7	423310	1	BRAKE DRUM - 180
8	423276	2	BRAKE SHOE
9	106753	2	3/32 X 3/4 COTTER PIN
10	423296	1	BRAKE CAM
11	423308	1	BRAKE CAM ARM
12	108500	1	E-RING FOR 5/8 DIA
13	423281	2	BRAKE SPRING
14	532028	1	BRAKE CONTROL -LH
15	423350	1	BRAKE LINK
16	363029	1	.312 ROD SWIVEL
17	423128	1	PARK BRAKE LINK
18	423130	1	PARK BRAKE SWIVEL
19	523112	1	5/16 CLAMP COLLAR
20	523024	1	SPRING
21	104256	1	5/16 NYLOC NUT
22	105258	1	5/16 FLAT WASHER
23	363177	1	3/8 PUSH NUT
24	363165	1	#3 HAIRPIN COTTER
25	105260	1	3/8 STANDARD FLAT WASHER
26	422086	1	Z-PARK LEVER W/GRIP
27	363105	1	IDLER BUSHING
28	100305	1	3/8-16 X 4 1/2 HHCS
29	523034	1	PARK BRAKE SWITCH
30	103023	1	1/2-20 LUG NUT
31	100501	1	1/4-28 X 1/2 HHCS
32	533024	1	WHEEL/TIRE ASM 23 X 9.5 X 12
32a	533069	--	DRIVE TIRE 23 X 9.5 X 12
32b	583058	--	RIM W/VALVESTEM
33	593181	1	WHEEL MOTOR SHAFT NUT - TJ
34	107013	1	5/16 X 1 (1001) WOODRUFF KEY

# X-TREME<sup>52</sup> Hydro Components

#	PART NO.	QTY.	DESCRIPTION
1	533153	2	PUMP W/RTN
2	453074	4	90° ADAPTER
3	583126	4	STRAIGHT ADAPTER
4	452121	1	OIL TANK W/CAP
5	423361	1	OIL FILTER
6	583406	1	OIL TANK CAP ( INTERNAL THREAD)
6a	453375	1	OIL TANK CAP (EXTERNAL THREAD)
7	583325	2	WHEEL MOTOR
8	453127	2	PUMP TO PUMP FEED LINE
9	453106	2	SWIVEL TEE
10	593073	1	HOSE RETURN
11	423373	1	PUMP FEED LINE - Z
12	533147	1	RUBBER LINE L. OUTSIDE (LOPTM)
13	593287	4	ADAPTER SHORT
14	533146	1	RUBBER LINE L. INSIDE (LIPBM)
15	533145	1	RUBBER LINE R. INSIDE (RIPTM)
16	533148	1	RUBBER LINE R. OUTSIDE (ROPBM)
17	107013	2	5/16 x 1 (1001) WOODRUFF KEY
18	593181	2	WHEEL MOTOR SHAFT NUT - TJ

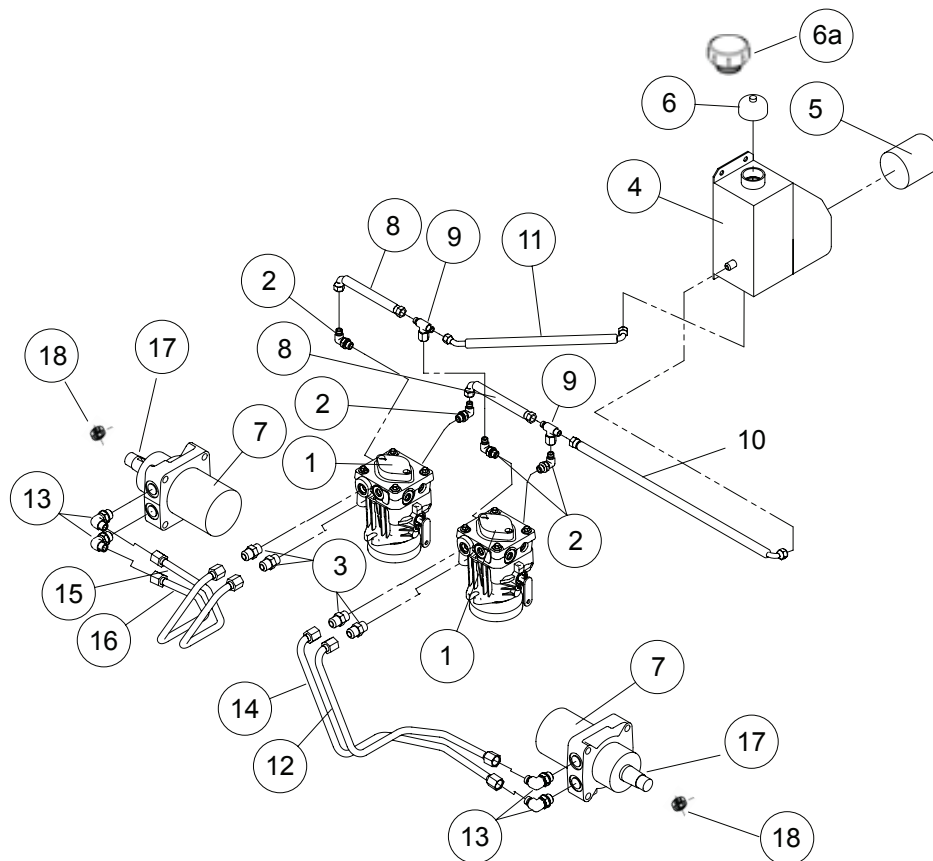

## Fuel Components

#	PART NO.	QTY.	DESCRIPTION
1	583050	1	FUEL VALVE
2	533085	1	FUEL LINE - 21 1/2"
3	583185	1	FUEL LINE - 39"
4	583186	1	FUEL LINE - 29"
5	363098	6	FUEL LINE CLAMP
6	105005	12	5/16 LOCK WASHER
7	100271	12	5/16-18 X 3/4 HHCS
8	823179	2	FUEL CAP - LARGE
9	583183	2	FUEL TANK ADAPTER
10	533125	2	VALVE GROMMET
11	533181	1	FUEL TANK / FENDER LH
12	533180	1	RH FUEL TANK

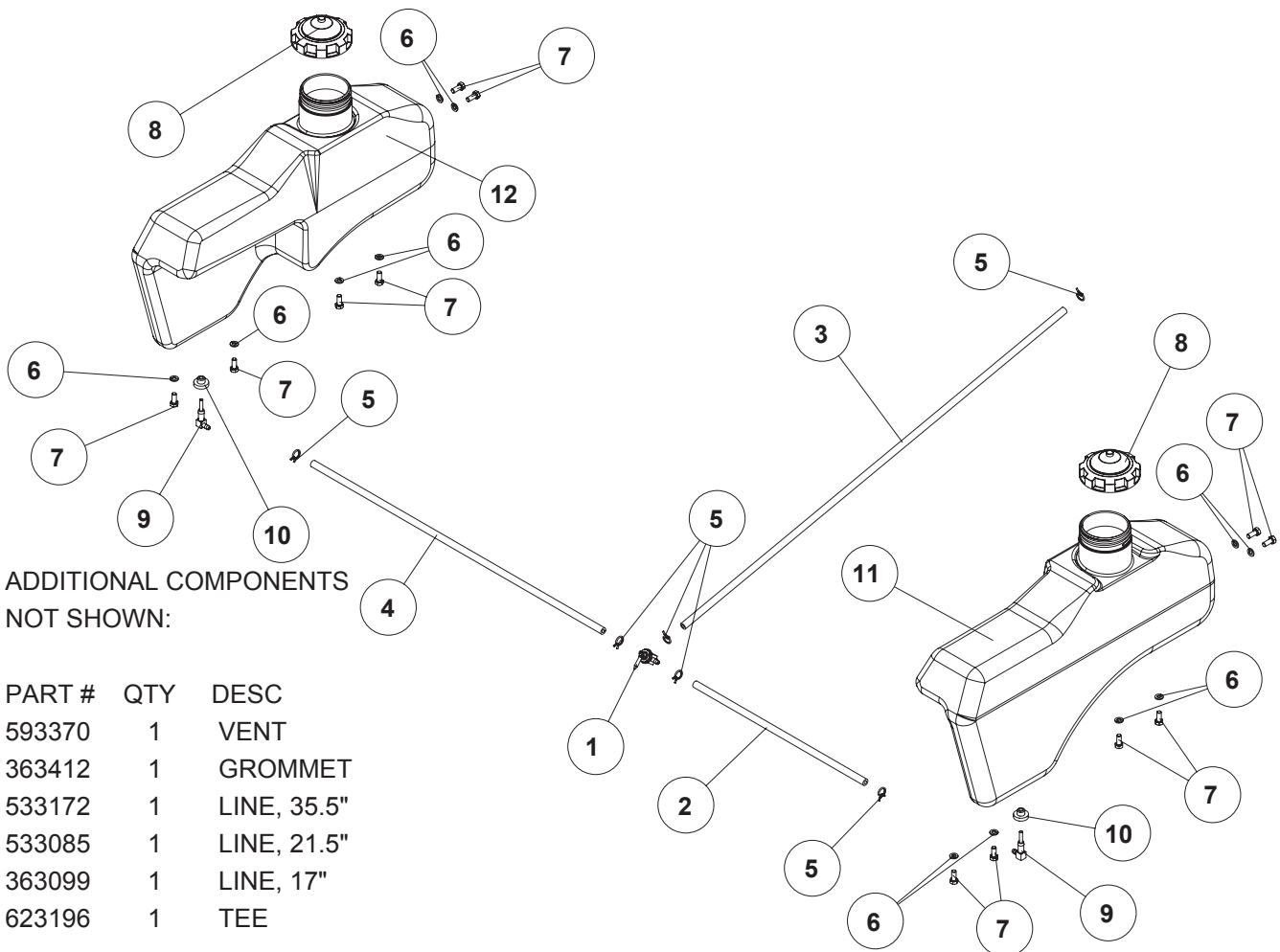

DECALS USED ON FUEL TANKS



14



15



16

PART NO.	QTY	DESCRIPTION
533177	2	DECAL, XTREME
533179	2	DECAL, ZX
363243	2	DECAL, ENCORE



# X-TREME<sup>52</sup> Decal List



1



2

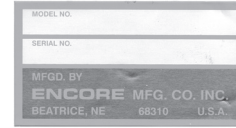

3

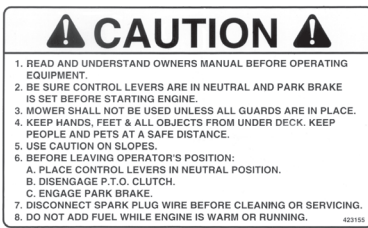

4

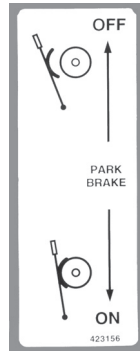

5

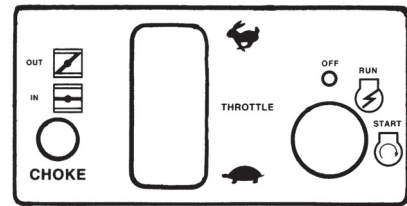

6



7

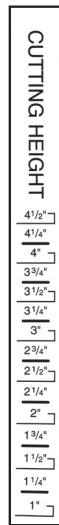

8

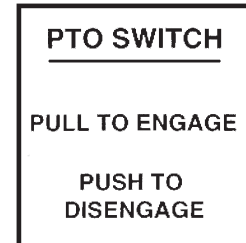

9

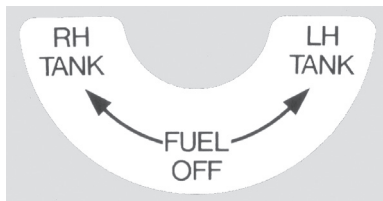

10



11



12

# X-TREME<sup>52</sup> Decal Lish

#	PART NO.	QTY.	DESCRIPTION
1	363001	1	CAUTION DECAL
2	363023	2	DANGER DECAL
3	363026	1	SERIAL NO. PLATE
4	423155	1	RIDER CAUTION DECAL
5	423156	1	PARK LEVER DECAL
6	423197	1	CONTROL DECAL
7	423354	1	OIL DECAL - SYN.
8	423379	1	CUT GAGE DECAL
9	523021	1	PTO DECAL
10	583023	1	LABEL - FUEL VALVE
11	823320	1	BATTERY WARNING DECAL
12	533057	1	FRONT X52 LABEL
13	423196	1	BELT ROUTING DECAL

# Notes

---

